

مستدير يتمركز تعدد اكتب دولكس 2205. الفولاذ المقاوم للصدأ الزجاج المشبك تجمع السياج حنفيه لمدة 1/2 "سمك زجاج وبعد

1. rbm، ميزات. الفولاذ المقاوم للصدأ الزجاج المشبك حمام السباحة سياج حنفيه لمدة 1/2 "الزجاج.

ديجوت الجسم	دولكس 2205.
المواد للبراغي، غطاء أساسي، لوحة التسوية	الفولاذ المقاوم للصدأ 316
إنهاء	نحى / مصقول / أسود / ذهبي
سمك الزجاج	الزجاج سمك 10-13.52mm
ارتفاع	أو يمكن تخصيصها 168mm.
طوقا بلاستيكية	مصنوعة من مواد النايلون، يمكن أن تستمر لفترة مدى الحياة
التراس الخرسانة لتناسب	M8 * 100.
وحدة الوزن لكل جهاز كمبيوتر	كجم 1.2
في الأوراق المالية	نعم
موك	جهاز كمبيوتر شخصى 2

2. زجاج حنفيه RBM أبعاد من.

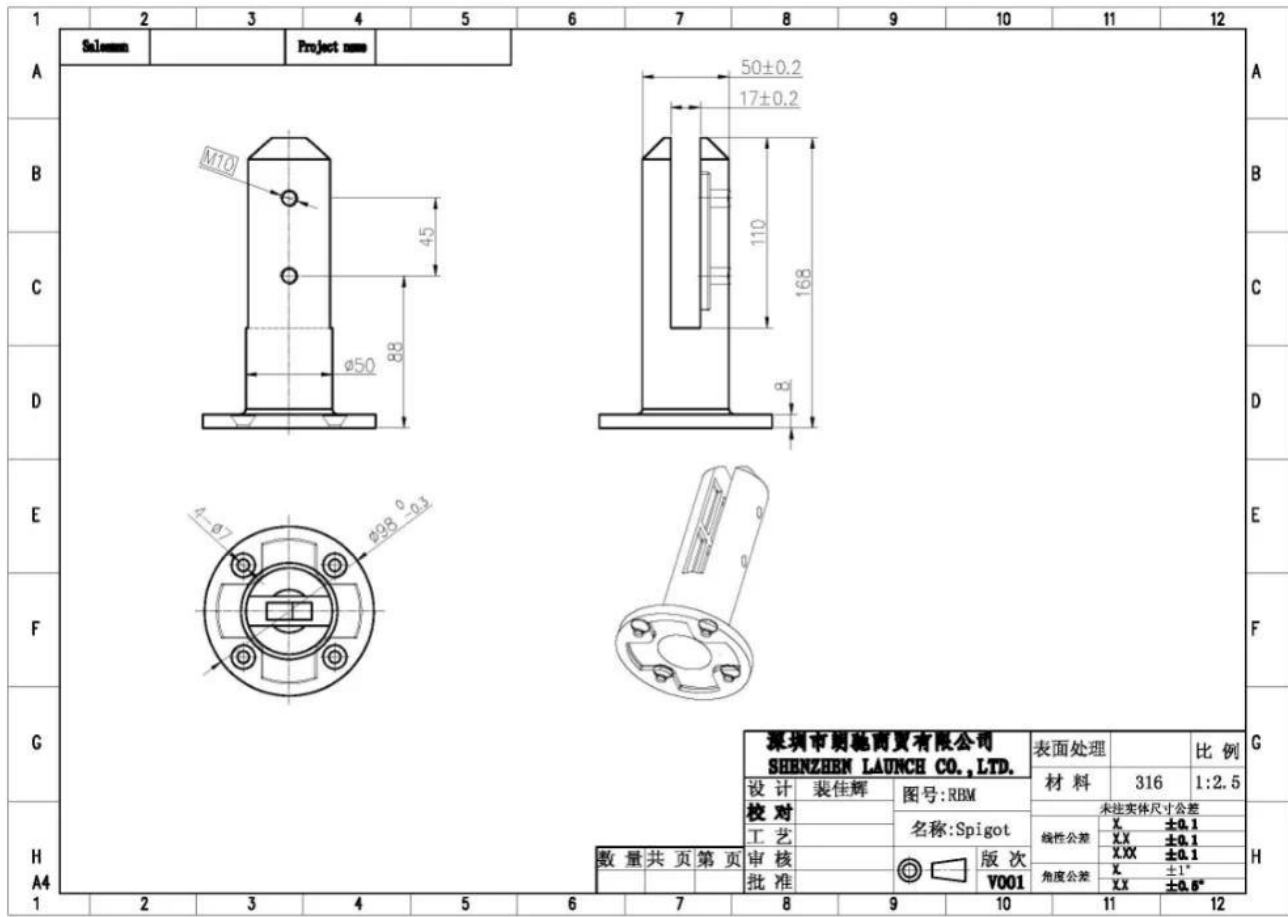

3. جار التحميل امتحان & مادة الفولاذ المقاوم للصدأ زجاج المشبك تجمع سياج سياج.

LOADING TEST FOR SBM

Introduction

MTS Metallurgical Testing Services was engaged to witness the installation of a sample pool fence spigot and to subsequently conduct load tests on the spigot to the requirements of Australian Standard AS1926.1 - 2012.

Standard/Specification AS 1926.1 - 2012, Section 3.2 and Appendix B

Results Summary

(For details of individual tests, refer to the tables on the following pages.)

ID	Item/Heat No.	Dimensions/Type/Details	Finish	Overall Assessment
14117/01	SSRM316	70mm Square, Base Plate 316 Stainless steel	316l	COMPLIES

Remarks

After completion of the testing, the spigot was found to be in sound condition with no breakage, tearing or signs of fracture and no looseness of the fixings.



Colin Cousins
Metallurgical Testing Manager



Accreditation No: 15624
Accredited for compliance
with ISO/IEC 17025

Strength Test

Test Specification AS 1926.1 - 2012, Appendix B Test Procedure MTS-TP3.1 Compression Tests - Products

Specimen ID	Observations	Assessment
14117/01	Test Equipment: Hydraulic ram and 10,000 N load cell Test Load: 330N Load Duration: 45 Secs Deflection under load: 1 mm Permanent Deflection after removal of test load: 0 mm	COMPLIES

Requirements No permanent damage or loosening of fixings.



12/16/2020 5:54:18 PM

Method: Fe-30
Comment: Cr-, Cr/Ni-steel
Type Standard 18--8

12/16/2020 5:54:09 PM

Type corr.concentr.

Sample Name:

Sample ID:

	C	Si	Mn	P	S	Cr	Mo	Ni
	%	%	%	%	%	%	%	%
< x > (1)	0.0224	0.8873	1.1010	0.0263	0.0032	21.6796	3.0718	5.5691

	Al	Co	Cu	Nb	Ti	V	W	Pb
	%	%	%	%	%	%	%	%
< x > (1)	< 0.0005	0.0797	0.1603	< 0.0002	0.0044	0.0893	0.0305	< 0.0002

	Sn	Sb	B	N	Fe			
	%	%	%	%	%			
< x > (1)	0.0092	< 0.0004	0.0024	0.1024	67.1600			

-زجاج حنفية IRBM التركيب تعليمات بالنسبة. 4-



fixing method: base plate spigots

Mark out the centre line of proposed glass fence with a chalk line. Determine clamp location based on a sheet size (recommendation on pages 1 & 2). Use base plate as a template to mark out the hole positions and drill holes to suit.

Note: Do not exceed 100mm gaps between glass panels. Optimum gap is 40mm to 60mm

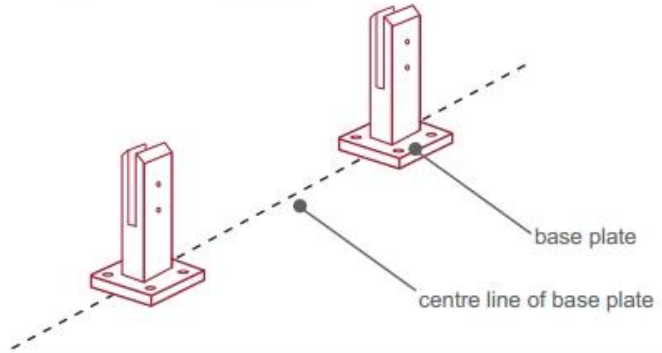

Now the base plated spigots can be fitted to the floor and plumbed via shims (not supplied) under the base plates. Be sure to tighten firmly as the smallest of movement at the base plate will result in noticeable movement at the bottom of the glass fence.

Tip: By setting the two outer spigots of your total span, a string line can be run in the 'throat' of the spigots, giving correct height for all spigots in between

Note: Do not exceed 100mm gap from the fixing surface to the bottom of the glass

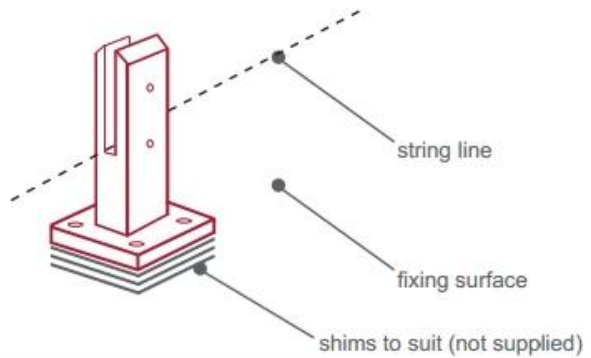

When all spigots are installed, slip domical cover the top of the spigot to hide fixings. It will be necessary to turn the adjustment screws on the spigot face all the way in to allow cover to pass over

Note: Same installation method applies to round base plate spigot

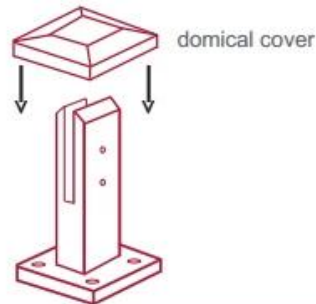

The glass is then installed to the spigots. Place plastic packers between glass & spigot, at no stage should glass touch the metal

How adjustability works:

1. Place glass in spigot
2. Fix/ tension glass both sides with allen key

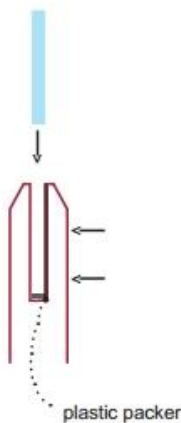

5. IRBM-التعبئة تفاصيل بالنسبة.

قطعة في مربع أبيض؛ 12 جهاز كمبيوتر شخصى في الكرتون 1







- رجاج حنغية SSBM كتلة إنتاج معالجة بالنسبة. 6





-أكثر عارضات ازياء من زجاج حنفيه بالنسبة لك اختيار. 7-



Glass spigot



MODEL # SBM



MODEL # SCM



MODEL # RBM



MODEL # RCM

-المشروع الصور من فرمليس زجاج السور مع زجاج حنفية. 8-

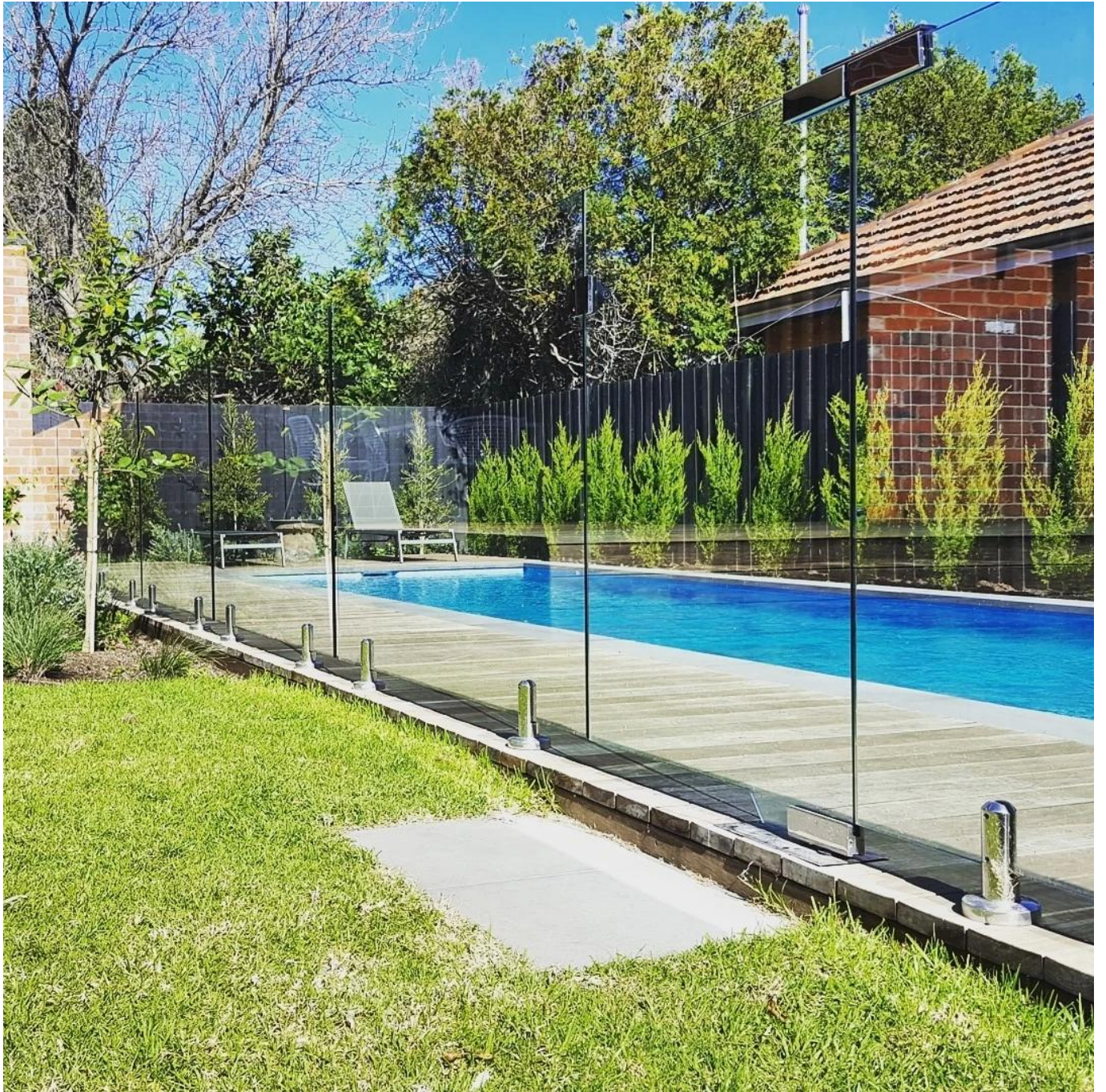

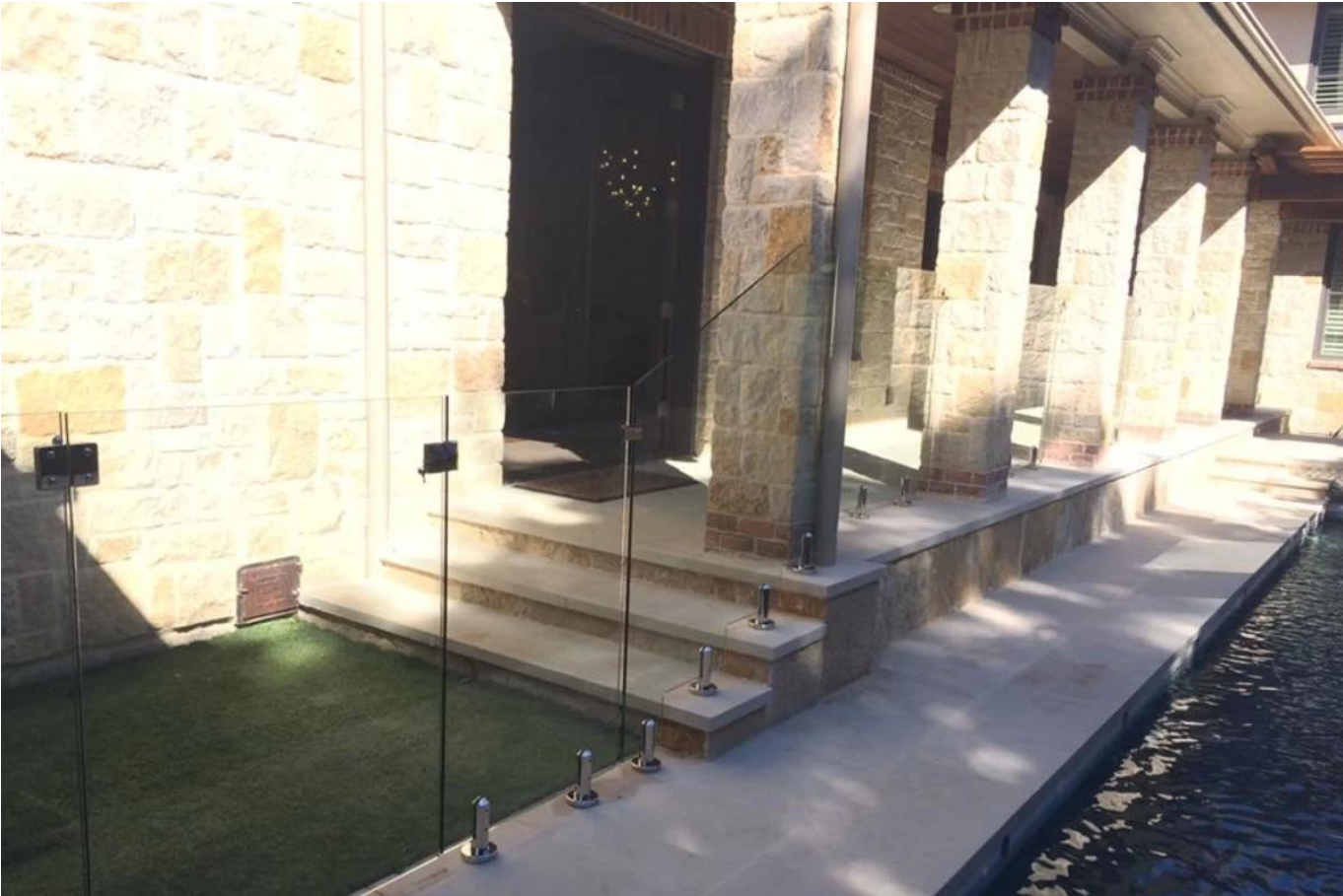







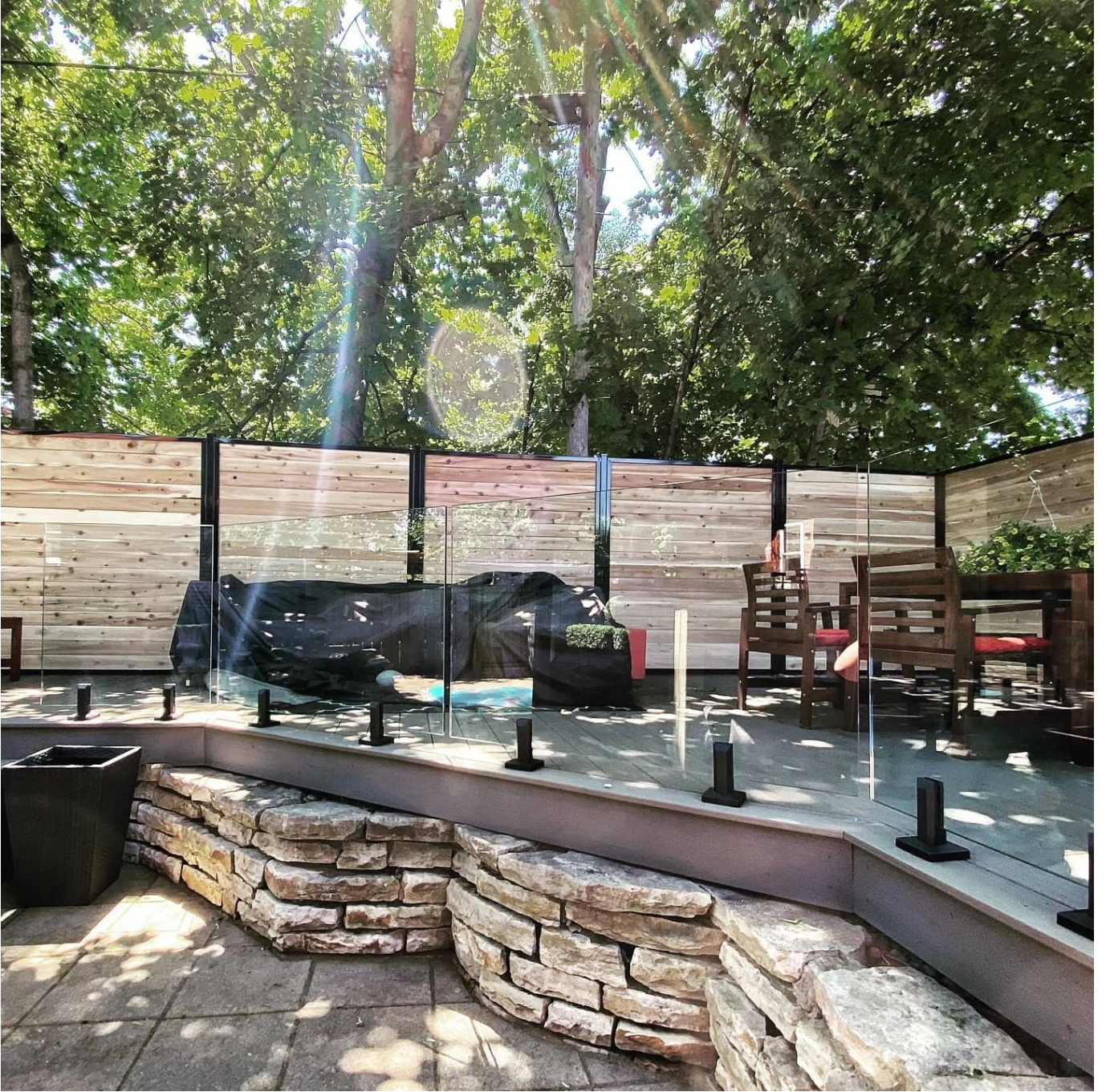

لدينا أيضا المفصلات الزجاجية والمكتل المغناطيسية ومشابك الزجاج والزجاج المقسى للذهاب مع نظام حديدي كامل بدون فرملس.

! لا تتردد في الاتصال بنا الآن للحصول على عروض الأسعار

شنتشن إطلاق المحدودة

SGS 19536352 P + T

مكتب إضافة:

مبنى يليدا، رقم 1092 طريق نانشان، مقاطعة نانشان، شنتشن، الصين، الرمز البريدي 518054، B5-003، 5 / F-Block 3،

الهاتف: 86037559-755-86 الفاكس: 86372611-755-86

اتصال: سيلياشن (Whatsapp, Wechat, Viber) +86 135 9027 3543

اتصال: سيلياشن

