

دوبلكس 2205 الفولاذ المقاوم للصدأ مربع سطح الزجاج حنفية لفرملس الزجاج السور للسباحة، باكلوني، تيرارس، الدرج الخ

وصف المنتج

المنتج مآنا	دوبلكس 2205 الفولاذ المقاوم للصدأ مربع سطح الزجاج حنفية
مواد	2205 / دوبلكس 316 الفولاذ المقاوم للصدأ
إنهاء	مرآة مصقول / الساتان نحى
Thickness إلى عن على غلاسنس	8-13.52mm
ارتفاع	168mm
حنفية قاعدة الحجم	100x100mm
الوزن الصافي	قطعة / 1.577kg
طريقة التصنيع	(صب جودة عالية)
تفاصيل التعبئة	قطعة واحدة في كيس فقاعة واحدة، ثم في مربع أبيض واحد (1) مليمتر الكرتون كرتون (2 x330x230) 12 أجزاء في 365 (3) التعبئة حسب متطلبات العملاء
الوضعية	حمام سباحة سياج، شرفة الزجاج حديدي، سطح فرملس الزجاج حديدي، سلالم
الكاتيون Certifi	إيت أستراليا ونيوزيلندا المعايير M. نعم فعلا
فسيح S	متاح
موك	حاسب شخصي 1
الخدمات ODM أوم & أمب؛	متاح

2205 Destails

1)

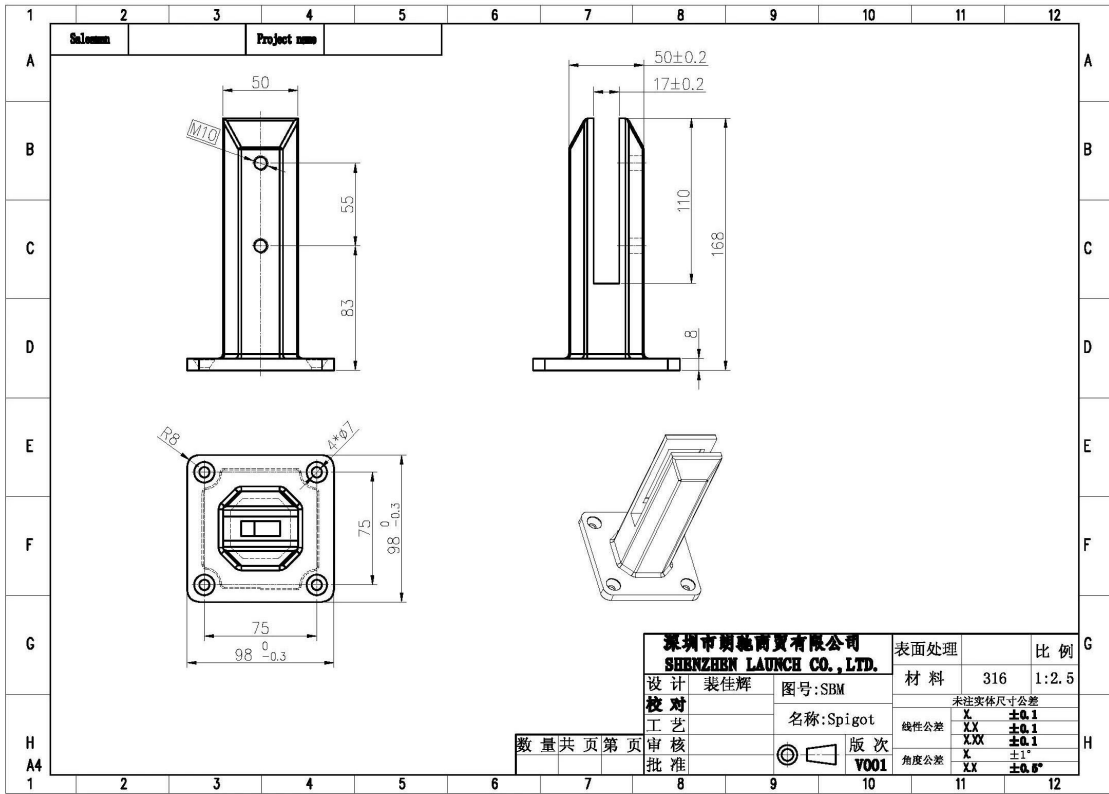

□□□□ □□□□□ □□ □□□ □□□□ □□□□□□ □□□□□□ 2205 □□□□□□ (2)

KEBIL 科比奥®







3) دليل التثبيت ل دوبلكس 2205 المقاوم للصدأ مربع سطح الزجاج حنفية



fixing method: base plate spigots

Mark out the centre line of proposed glass fence with a chalk line. Determine clamp location based on a sheet size (recommendation on pages 1 & 2). Use base plate as a template to mark out the hole positions and drill holes to suit.

Note: Do not exceed 100mm gaps between glass panels. Optimum gap is 40mm to 60mm

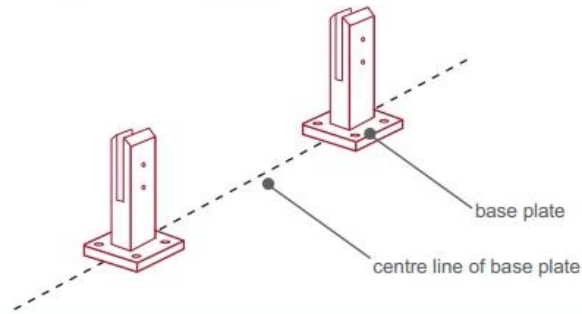

Now the base plated spigots can be fitted to the floor and plumbed via shims (not supplied) under the base plates. Be sure to tighten firmly as the smallest of movement at the base plate will result in noticeable movement at the bottom of the glass fence.

Tip: By setting the two outer spigots of your total span, a string line can be run in the 'throat' of the spigots, giving correct height for all spigots in between

Note: Do not exceed 100mm gap from the fixing surface to the bottom of the glass

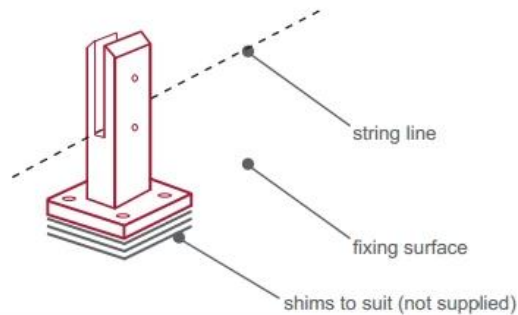

When all spigots are installed, slip domical cover the top of the spigot to hide fixings. It will be necessary to turn the adjustment screws on the spigot face all the way in to allow cover to pass over

Note: Same installation method applies to round base plate spigot

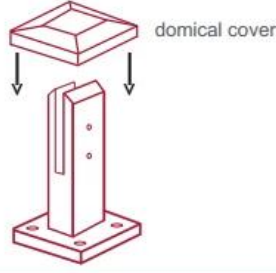

The glass is then installed to the spigots. Place plastic packers between glass & spigot, at no stage should glass touch the metal

How adjustability works:

1. Place glass in spigot
2. Fix/ tension glass both sides with allen key

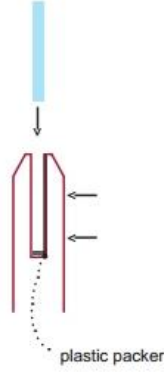

سلامة التعبئة والتغليف ل دوبلكس 2205 المقاوم للصدأ مربع سطح الزجاج حنفية

1. قطعة واحدة في كيس فقاعة واحدة، ثم في مربع أبيض واحد. 365 ملليمتر كرتون الكرتون. 12 أجزاء في 330x230
2. التعبئة كما ريكوريمنتس العملاء.



دوبلكس 2205 الفولاذ المقاوم للصدأ مربع سطح زجاج حنفيه المشاريع





التعليمات

1. ما المواد هل لديك؟

دوبلكس 2205، إلخ، SS304، SS316، SS316L،

2. يمكنك أن ترسل لي قائمة الأسعار بأكملها؟

آسف، كما يرتبط السعر إلى العديد من العوامل، مثل كمية، نوع المادة، المعالجة السطحية وهلم جرا، وسوف نقدم لكم اقتباس بالضبط بعد أن نؤكد متطلبات مفصلة.

3. هل تقدم أوم & أمب؛ أودم الخدمة؟

نعم، يمكننا تقديم المنتجات وفقا الرسومات الفنية أو العينات. نحن المهنية في الاستثمار الصب، يموت الصب، ختم، التصنيع باستخدام الحاسب الآلي، إلخ.

4. وات نوع الدفع تقبل؟

باي بال، اتحاد غرب، إلخ. C، // تي تي، ل

5. وات هو مصطلح الدفع؟

في الافق. C / ا أو t / t (30/70)

6. وات هو وقت التسليم؟

خلال 5 أيام عمل ل حار بيع البنود. 15-25 أيام عمل ل أوامر الحمام.

7. هل تقدمون بعد-- خدمة بيع؟

بالطبع، أي سؤال بعد شراء منتجاتنا، وسوف نعود اليكم خلال 24 ساعة.

معلومات الشركة

Shenzhen Launch Co., Ltd was established in 2004, located at Nanshan District, Shenzhen, and one hour by car from Hongkong International Airport. Our main product is high-grade building materials includes stainless steel balustrade post, staircase handrail, balcony guardrail, swimming pool fence and other high-grade building materials. All the products are designed strictly according to the high-end market requirements. We have our own factory in Tangxia Town, Dongguan, has a variety of precision equipment more than 50 sets: CNC lathe, milling machine, punching machine, pipe cutter, argon welder, drilling machine, polisher, etc. which can provide customers with complete product processing services. With the German SPECTRO Spectrometer, we insist on testing every batch of materials to ensure that the material is highly qualified. We also have hardness gauge, secondary element and other test equipment to ensure the products meets customers' requirements.

ABOUT US



OUR ADVANTAGE

Please do not hesitate to contact us if you have any requirement regarding our production lines, you can expect a timely reply with professional solutions!



Own factory, shortest lead time.



Can help customers design product drawings based on customer ideas and design engineering installation drawing according to the customer site sketch.



Sample order, trial order acceptable.



Provide material test report to ensure that the material is qualified.



13 years of industry experience, we can help customers recommend the best solution to help customers save cost.

OUR FACTORY

More than 13 years experience in hardware industry design and processing, we can provide customized services from design to the sample and small batch trial production.



OUR CERTIFICATE

With premium quality, competitive price and superior service, we won a lot of customers' favor.
Our products are popular in North America, European and Australia.



PRODUCTION PROCESS



Casting



CNC lathe



CNC Milling



Stamping



Drilling & Tapping



Polishing



PACKAGING & DELIVERY



PAYMENT & TRANSPORTATION

Welcome Alibaba Trade Assurance Order!

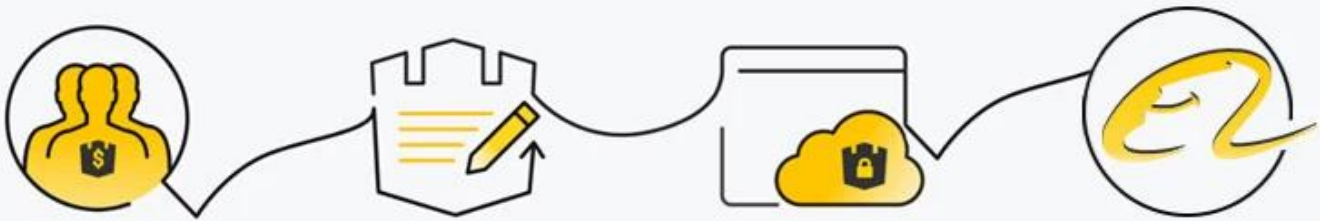

- 1 Start an order
- 2 Negotiate terms with our sales service & confirm order
- 3 Make payment
- 4 Alibaba provide full assurance



CONTACT US

WELCOME TO CONTACT US. WE WILL DO OUR BEST TO HELP YOU!



CELIA CHEN



Email : sales01@launch-china.cn



Skype : launch-01



Mob. 86-13590273543

