

Barandilla de vidrio sin marco para balcón de 50 mm diámetro vaso punto muerto tornillos pared montar , ininterrumpido puntos de vista !

La barandilla de separación de vidrio se compone de pernos de separación de vidrio de acero inoxidable, paneles de vidrio templado (vidrio templado transparente de 10-19 mm de espesor o vidrio templado ultra claro), pasamanos superiores opcionales.

Características de los pernos de separación de vidrio:

- N ° de Modelo. SF-50
- Material: acero inoxidable 304/316
- cepillado o pulido
- Tapa de 50 * 12 mm, cuerpo de 50 * 30 mm, perno M12 * 120
- hecho por mecanizado cnc
- pernos de separación sólidos
- peso 715g
- otros diámetros de pernos de separación también disponibles 30 mm, 38 mm, 40 mm, etc.

fotos de pernos de separación de vidrio para barandas de vidrio sin marco de balcón -







SF-50



SF-50

dibujo de pernos de separación de vidrio sin marco

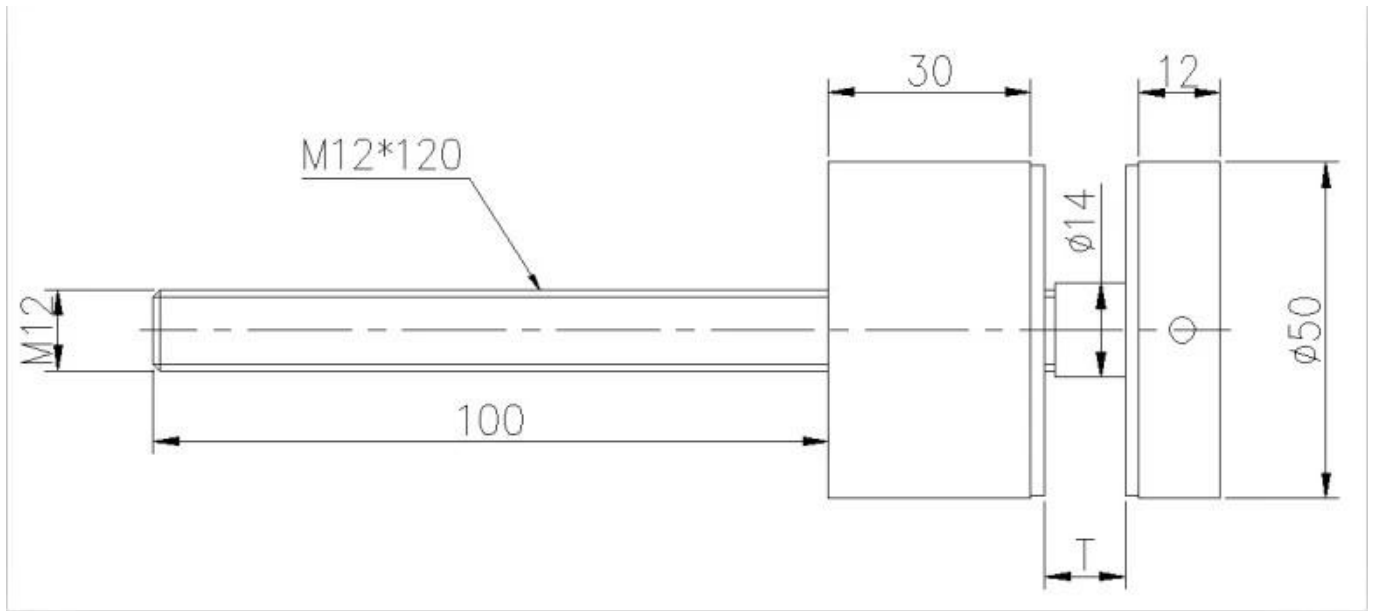

Fotos de embalaje de enfrentamiento de vidrio sin marco -



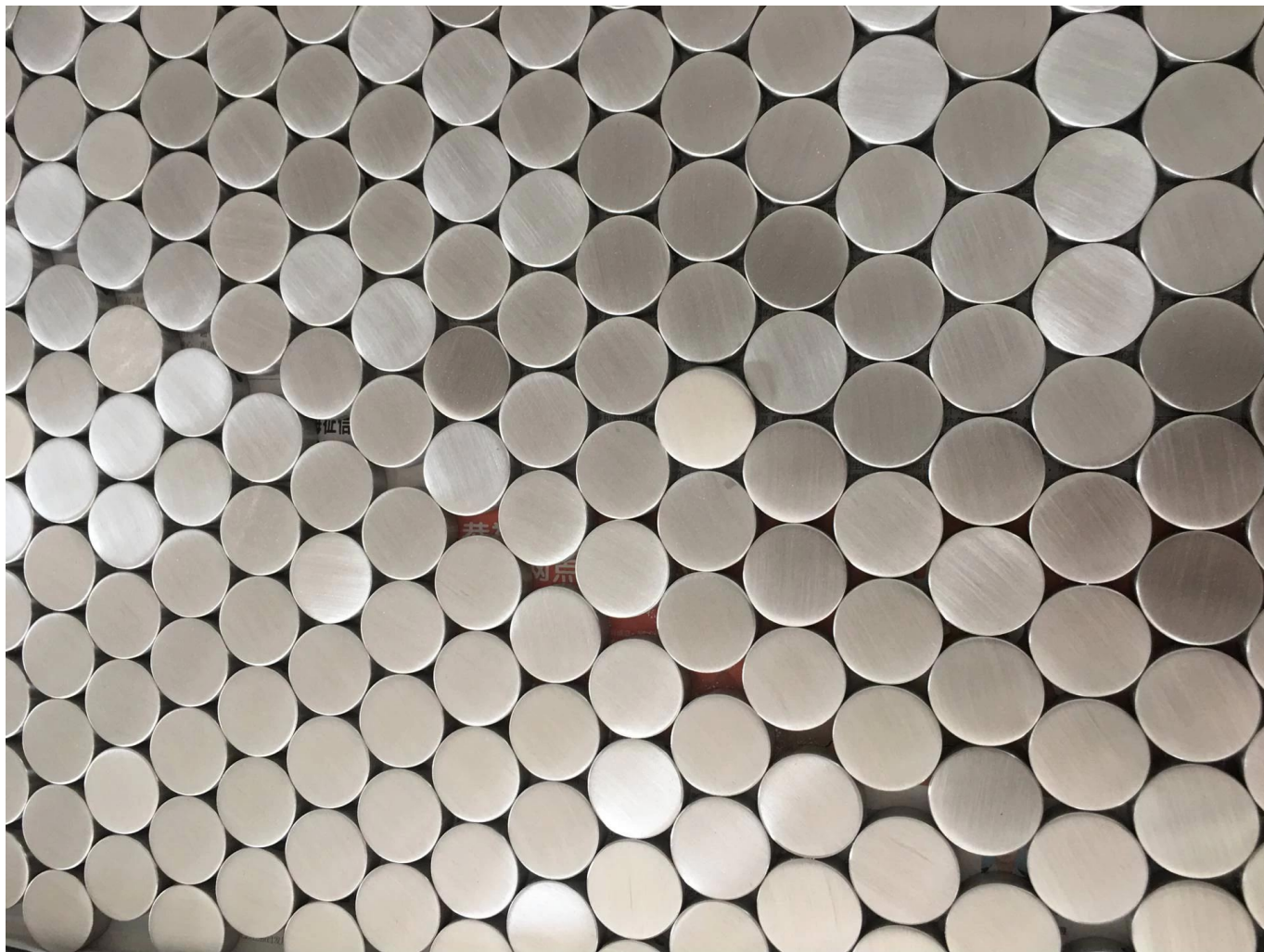



Proyecte fotos de barandas de vidrio sin marco con nuestros pernos de separación de vidrio.





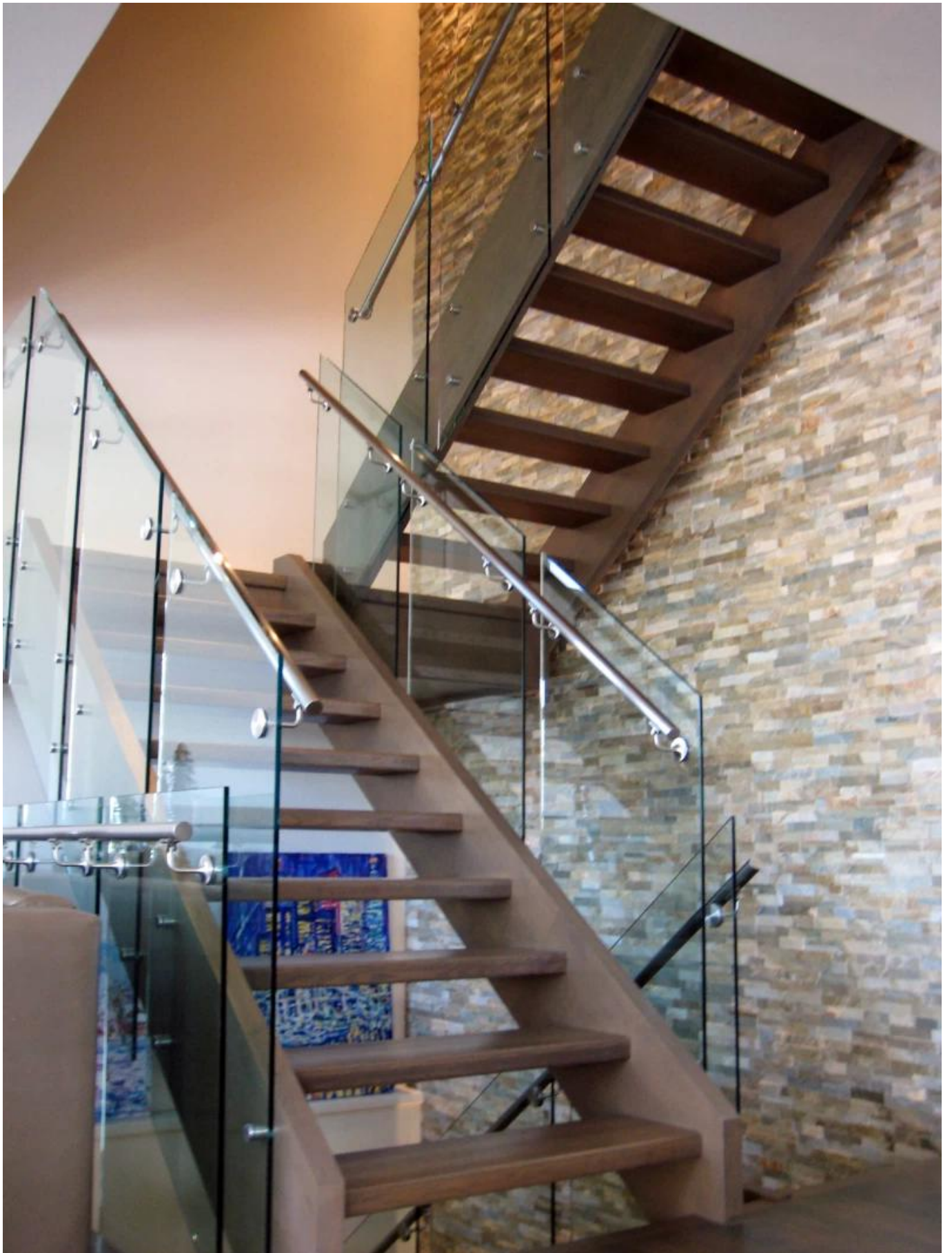



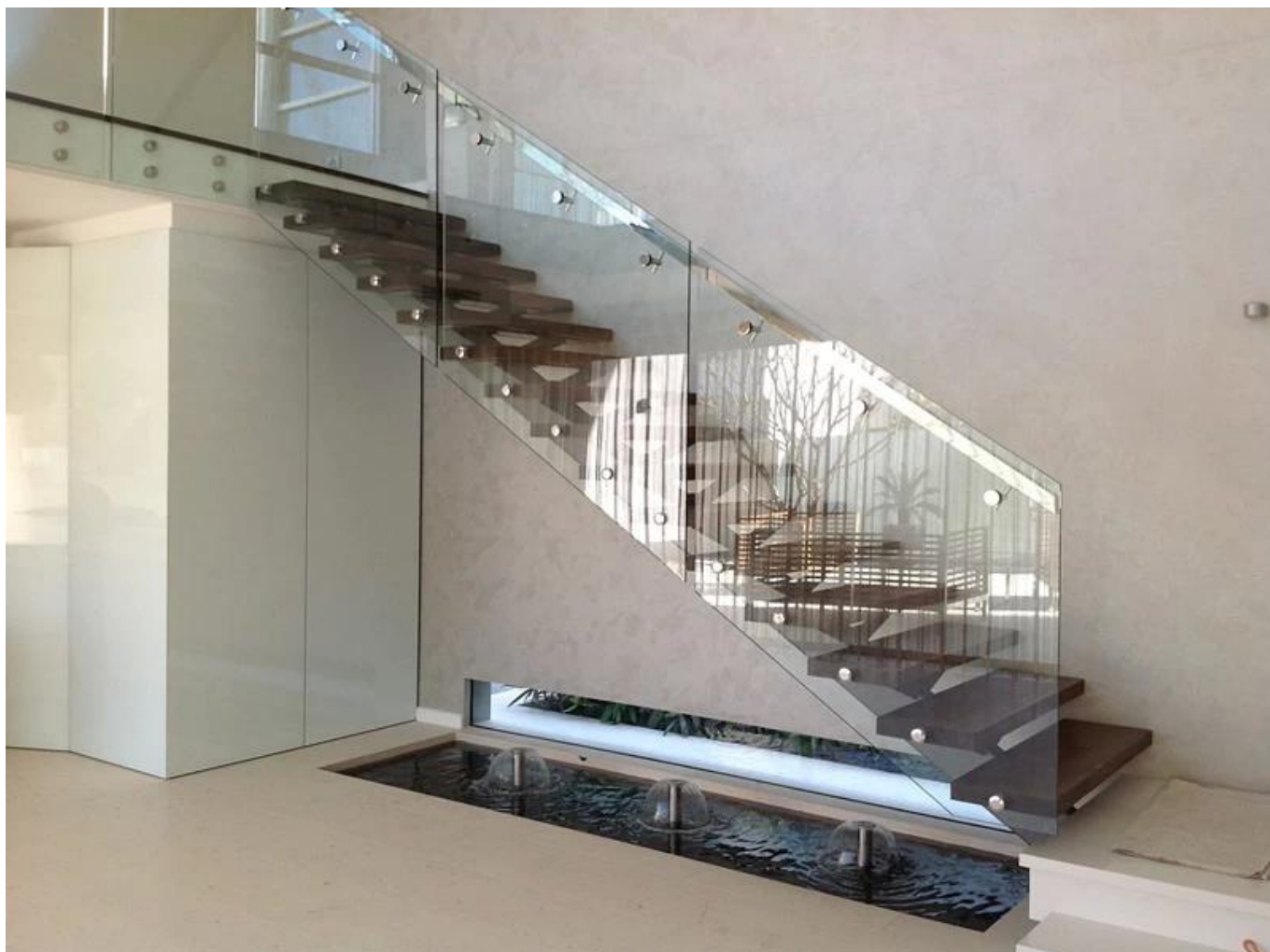

Más acerca de SHENZHEN LAUNCH CO. LTD-

Company profile

Shenzhen Launch Co., Ltd was founded in the year 2004, with full experience in below production lines:

1. Construction materials including stainless steel railing materials , handrail fittings ,clamps, brackets, flanges , stainless steel tubing /sheet etc.
2. Professional OEM services such as laser cutting, precision casting (Stainless steel and Titanium), metal punch, cold rolling precision tube (tolerance for inner and outer diameter can be controlled within plus/minus0.01mm), CNC machining, Al, Zinc alloy die casting, hardware welding, tube bending, water heater accessories, solar energy equipment accessories, auto parts, etc.

We have been supplying middle and high end construction materials / OEM fabrication parts to our main market in Europe , North America , Oceania , for more than 15 years . Recent years we have also been supplying our materials to Middle East , South America .



Laser cutting workshop



CNC machine workshop



Sheet metal & bending machine workshop



Stamping shop



160T 宽台面冲床 模具加工尺寸800*1800mm



Die making shop



Sample Show room



Project reference- Hot dip galvanizing parts for USA





Welding handrails for Australia



SS Front panel project for building in Australia



SS sheet panels



Steel tubing for USA



SS HANDRAIL FOR CANADA



Office address: B5-003, 5/F-Block 3, Yilida Building, No. 1092 Nanshan Road, Nanshan District, Shenzhen, China, postal code 518054

Tel: 86-755-86037559 Fax:86-755-86372611

Factory address in Dongguan : 1st floor, Building A, Ruixin Hengye No.3 industrial area, Taixing Road, Shigu Town, Tangxia district, Dongguan

Contacts:

Gao Binfeng –Managing director E. admin@launch-china.cn PH. 86-755-86037559

Celia Chen – Sales manager E. sales01@launch-china.cn PH. 86-755-86037559 MOB .+8613590273543

Jacky Pei – Chief Engineer PH . 86-755-86037559

