

Kehyksetön lasikaiteet duplex 2205 -lasit 10 mm - 13,52 mm: n lasilevyille.

Säädettävä duplex 2205 -lasin spigot on 4 ylimääräistä pientä reikää ja ruuvia pohjalevyssä ja 1 kpl-tasoisuuslevyä, jota käytetään säpyn pohjassa säätämään tasoa, kun maa ei ole edes.

1. Lasikaiteen ominaisuudet duplex 2205 -lasit

Materiaaliofspiittitärkeinrunko	Duplex 2205
Materiaali ruuveille, pohjakansi, tasoituslevy	316 ruostumaton teräs
Suurittaa loppuun	Matte musta jauhepäällyste tai sähköpinnoitus; satiini; peili
Lasipaksuus	10-13,52mm paksuuslasit
Korkeus	168mm; tai voidaan räätälöidä
Muovinen tiiviste	Valmistettu nailonmateriaalista, se voi kestää elinikäisen ajan
Betonipultti sopivaksi	M8 * 100
Yksikköpaino PC	1.45kg
Varastossa	Joo
Moq	2 kpl

2. Mitat of Sbm lasi-spigot-

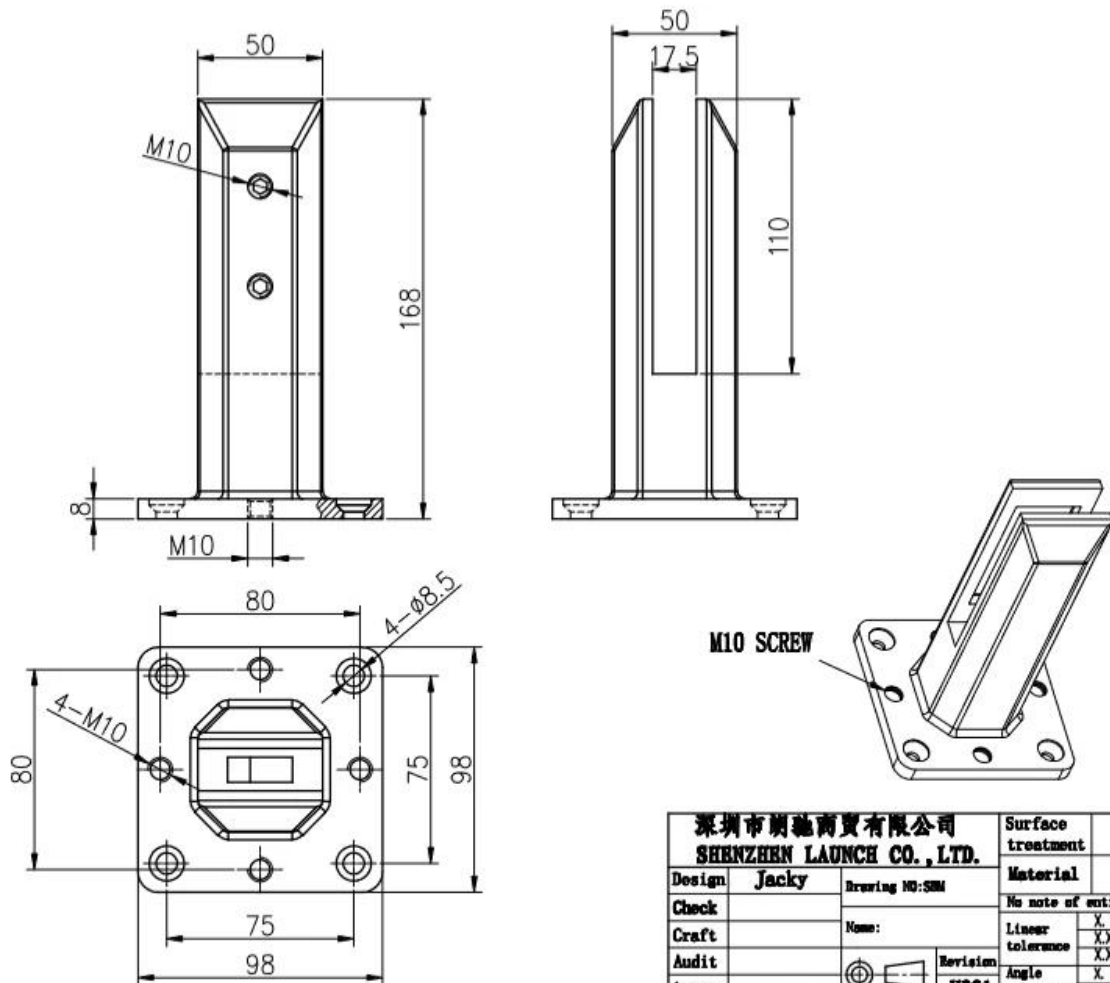

深圳市朗馳商貿有限公司 SHENZHEN LAUNCH CO., LTD.		Surface treatment	Preparation
Design: Jacky	Drawing NO: SSM	Material	1:2
Check	Name:	No note of entity size tolerance	
Craft		Linear tolerance	X ±0.1
Audit		XXX tolerance	±0.1
Approve	Revision	Angle tolerance	X ±1°
	V001	XXX tolerance	±0.05°

3.Ladataantestata& MateriaalitestatavartenSBM Duplex 2205lasi-spigot-



LOADING TEST FOR SBM

Introduction

MTS Metallurgical Testing Services was engaged to witness the installation of a sample pool fence spigot and to subsequently conduct load tests on the spigot to the requirements of Australian Standard AS1926.1 - 2012.

Standard/Specification AS 1926.1 - 2012, Section 3.2 and Appendix B

Results Summary

(For details of individual tests, refer to the tables on the following pages.)

ID	Item/Heat No.	Dimensions/Type/Details	Finish	Overall Assessment
14117/01	SSRM316	60mm Square, Base Plate 316 Stainless steel	316l	COMPLIES

Remarks

After completion of the testing, the spigot was found to be in sound condition with no breakage, tearing or signs of fracture and no looseness of the fixings.

Colin Cousins
Metallurgical Testing Manager



Accreditation No: 15624
Accredited for compliance
with ISO/IEC 17025

Strength Test

Test Specification AS 1926.1 - 2012, Appendix B Test Procedure MTS-TP3.1 Compression Tests - Products

Specimen ID	Observations	Assessment
14117/01	Test Equipment: Hydraulic ram and 10,000 N load cell Test Load: 330N Load Duration: 45 Secs Deflection under load: 1 mm Permanent Deflection after removal of test load: 0 mm	COMPLIES

Requirements No permanent damage or loosening of fixings.



12/16/2020 5:54:18 PM

Method: Fe-30
 Comment: Cr-, Cr/Ni-steel
 Type Standard 18--8

12/16/2020 5:54:09 PM

Type corr.concentr.

Sample Name:

Sample ID:

	C	Si	Mn	P	S	Cr	Mo	Ni
	%	%	%	%	%	%	%	%
< x > (1)	0.0224	0.8873	1.1010	0.0263	0.0032	21.6796	3.0718	5.5691

	Al	Co	Cu	Nb	Ti	V	W	Pb
	%	%	%	%	%	%	%	%
< x > (1)	< 0.0005	0.0797	0.1603	< 0.0002	0.0044	0.0893	0.0305	< 0.0002

	Sn	Sb	B	N	Fe			
	%	%	%	%	%			
< x > (1)	0.0092	< 0.0004	0.0024	0.1024	67.1600			

4.AsennusOhjeetvartenSbmlasi-spiggot-



fixing method: base plate spigots

Mark out the centre line of proposed glass fence with a chalk line. Determine clamp location based on a sheet size (recommendation on pages 1 & 2). Use base plate as a template to mark out the hole positions and drill holes to suit.

Note: Do not exceed 100mm gaps between glass panels. Optimum gap is 40mm to 60mm

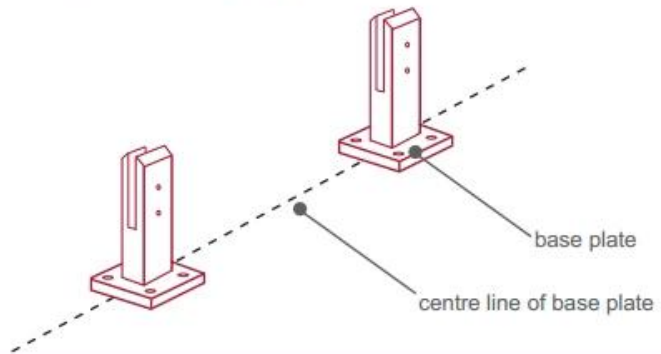

Now the base plated spigots can be fitted to the floor and plumbed via shims (not supplied) under the base plates. Be sure to tighten firmly as the smallest of movement at the base plate will result in noticeable movement at the bottom of the glass fence.

Tip: By setting the two outer spigots of your total span, a string line can be run in the 'throat' of the spigots, giving correct height for all spigots in between

Note: Do not exceed 100mm gap from the fixing surface to the bottom of the glass

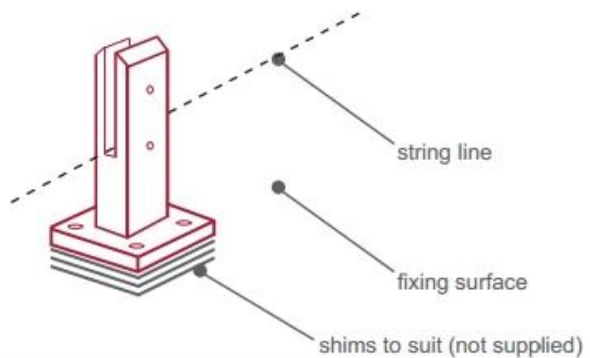

When all spigots are installed, slip domical cover the top of the spigot to hide fixings. It will be necessary to turn the adjustment screws on the spigot face all the way in to allow cover to pass over

Note: Same installation method applies to round base plate spigot

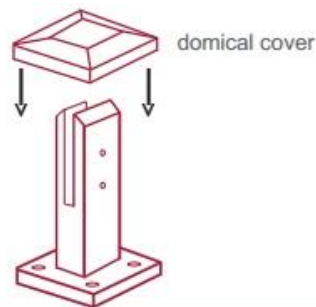

The glass is then installed to the spigots. Place plastic packers between glass & spigot, at no stage should glass touch the metal

How adjustability works:

1. Place glass in spigot
2. Fix/ tension glass both sides with allen key

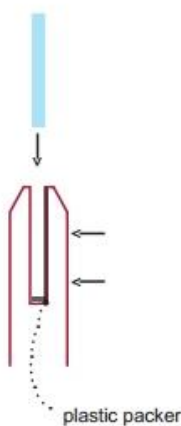

5.PakkausyksityiskohdatvarienSbmDuplex 2205 Glass Spigots-

1 kpl valkoiseksi laatikkoon; 12 kpl kartonki-



6.MassaTuotantoProsessivartenSbmlasi-spiltti-



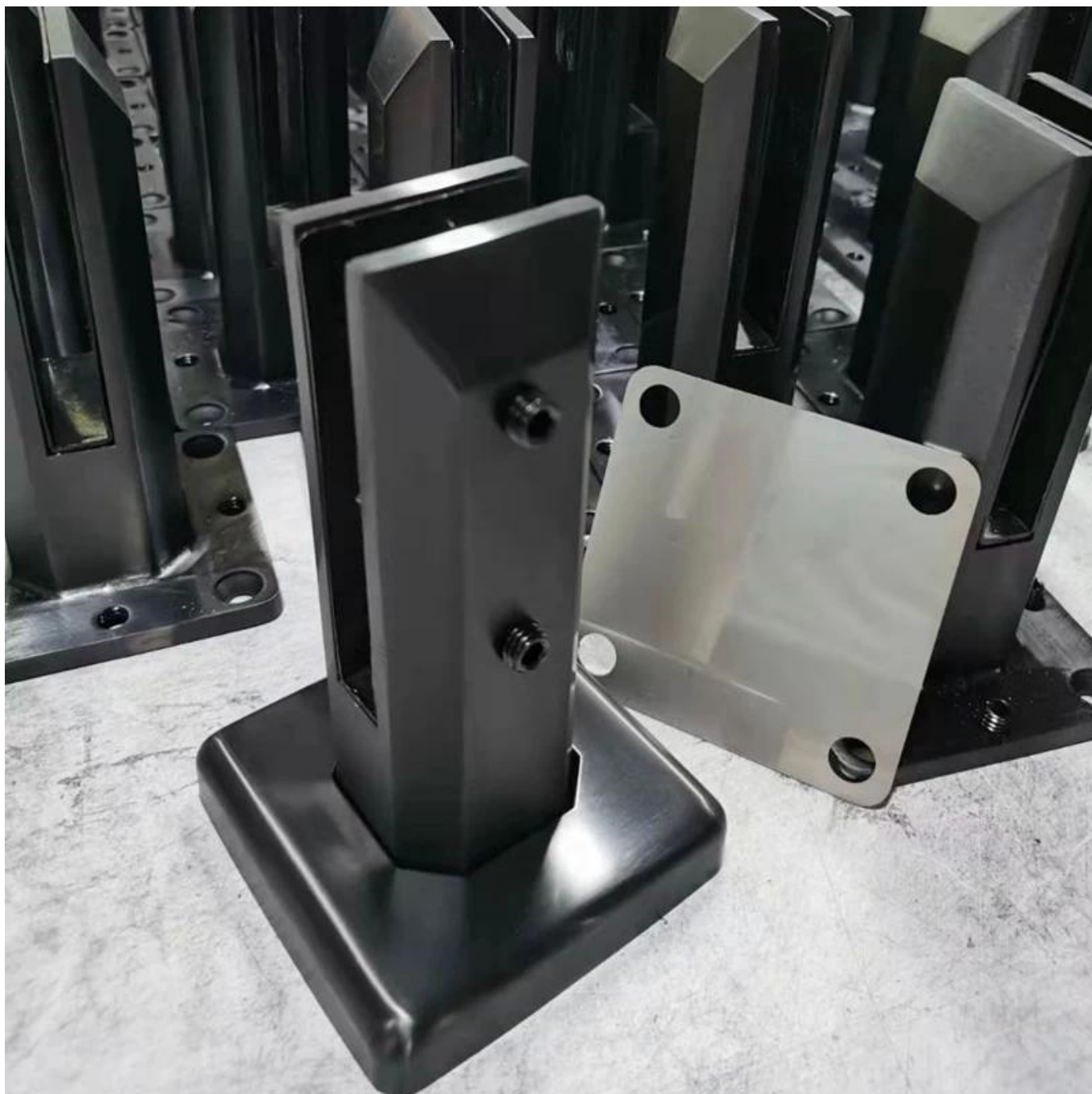

7.Lisäämallitoflasi-spilttivartensinunvalinta-





MODEL # SBM



MODEL # SCM



MODEL # RBM



MODEL # RCM

Glass spigot

8.HankeValokuvatofKehystönLasiKaiteetkanssalasi-piikit-





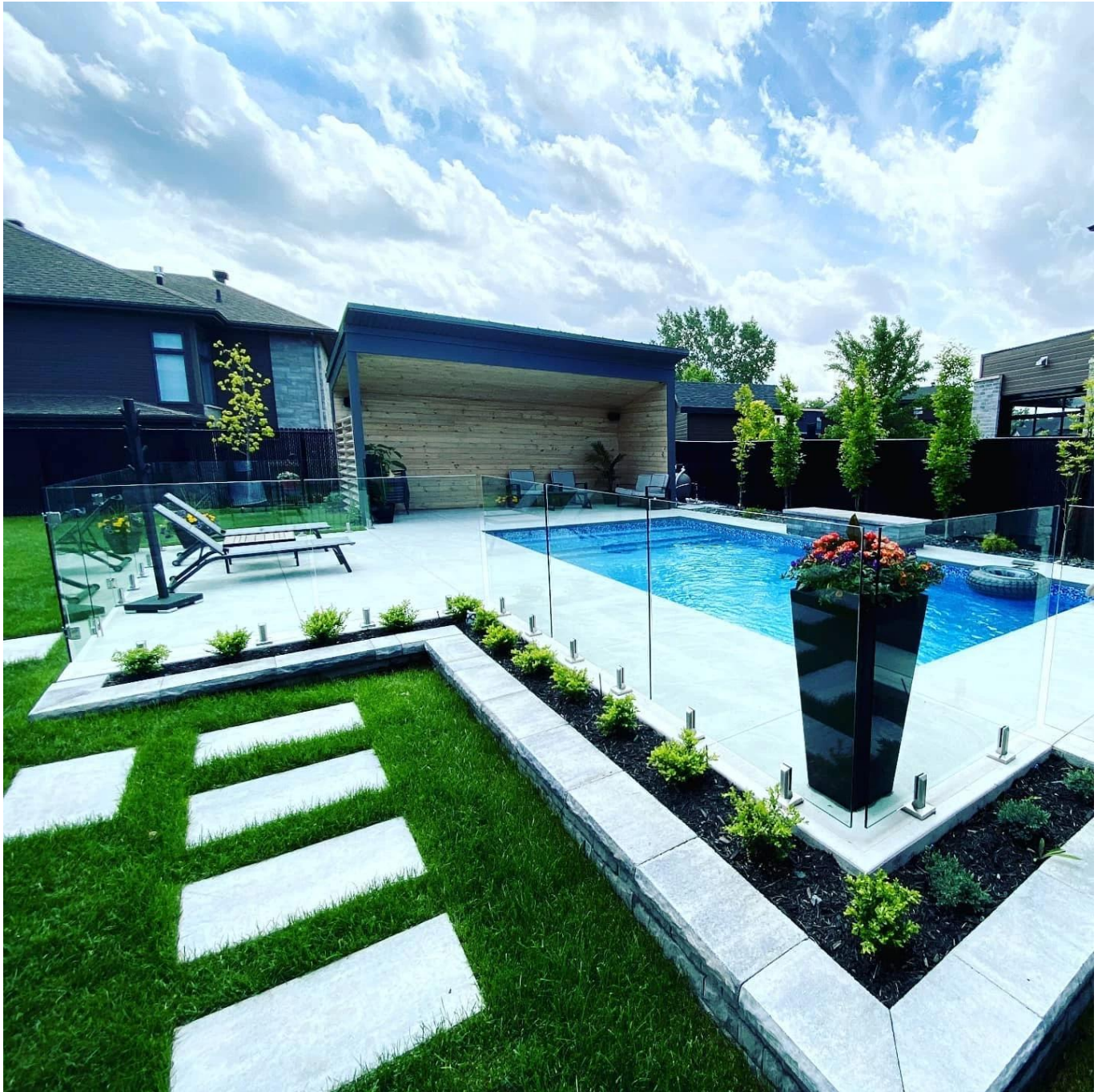

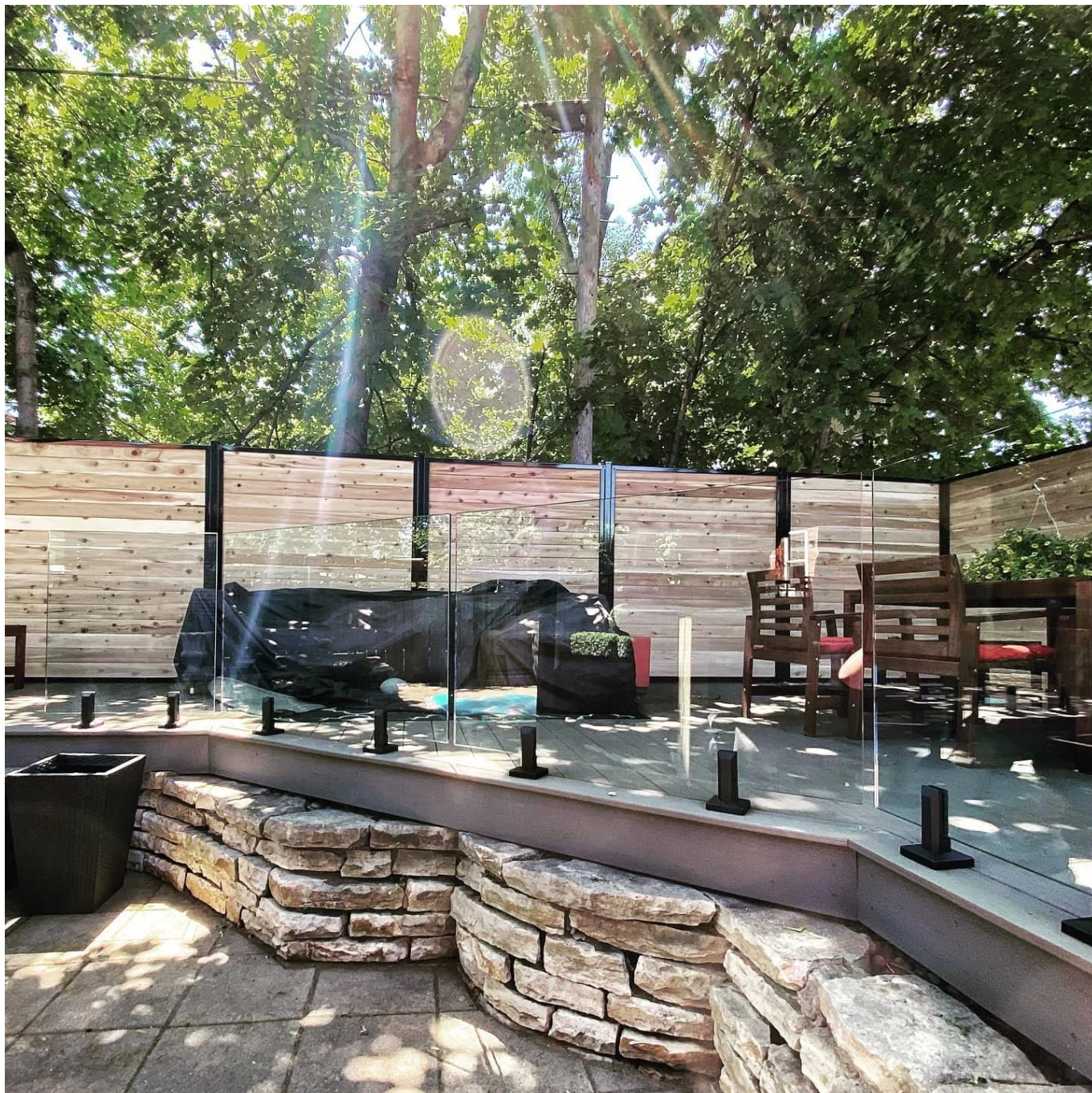

Meillä on myös lasin sarana ja magneettiset salvat ja lasilevyt ja karkaistu lasi mennä koko kehyksetön lasilevyllä.

Voit ottaa meihin yhteyttä nyt saadaksesi lainauksia!

Shenzhen Launch Co., Ltd

[Vahvistettu SGS, raportti nro 19536352_P + T](#)

Toimisto Lisää:

B5-003, 5 / F-lohko 3, YiliDa Building, nro 1092 Nanshan Road, Nanshan District, Shenzhen, Kiina, Postinumero 518054

Puh: 86-755-86037559 Faksi: 86-755-86372611

Mob (Whatsapp, Wechat, Viber) +86 135 9027 3543

Ottaa yhteyttä:CeliaChen