

Marine Grade Duplex 2205 Βάση βάσης Τετράγωνο γυάλινο βύσμα Αυστραλιανό πρότυπο για γυάλινο φράχτη χωρίς πλαίσιο.

Χαρακτηριστικά -

- Υπόδειγμα αρ. SBM
- Υλικό - duplex 2205, SS 316, SS316L, SS304
- Φινίρισμα - σατέν, καθρέφτης, μαύρο, χρυσό, λευκό κλπ.
- Ύψος 168 mm
- Βασικό κάλυμμα, πλαστικό ένθετο, ρυθμιζόμενες βίδες
- 1 τεμάχιο συσκευασμένο σε λευκό κουτί.12 τεμ σε κουτί

Γκαλερί φωτογραφιών -

KEBIL 科比奧®



KEBIL 科比奥®



KEBIL 科比奥®





Σχέδιο-

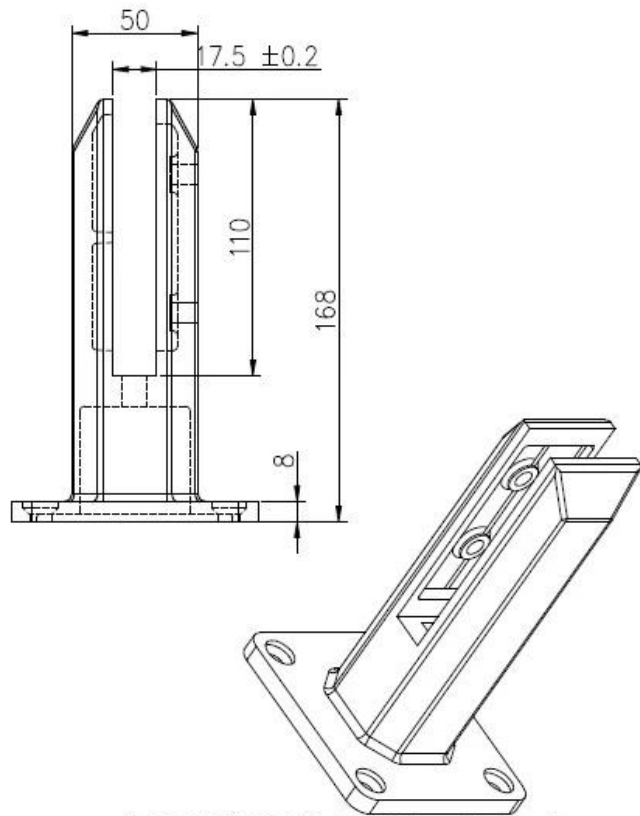
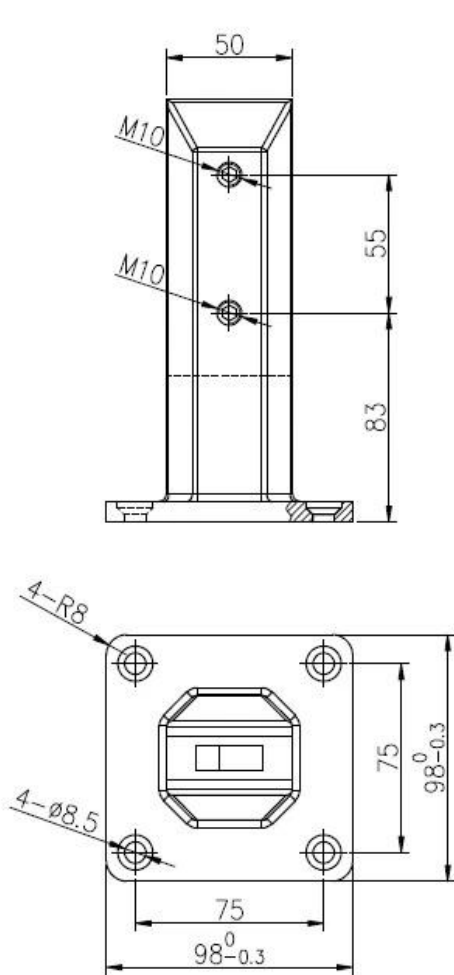

深圳市朗馳商貿有限公司 SHENZHEN LAUNCH CO., LTD.		Surface treatment		Proportio
Design	Jacky	Material	2205	1:1
Check		No note of entity size tolerance		
Craft		Linear tolerance	X.X ±0.1	
Audit		Revision	X.XX ±0.1	
		Angle	X ±1°	

Αναφορά δοκιμής υλικού Duplex 2205-



12/16/2020 5:54:18 PM

Method: Fe-30
Comment: Cr-, Cr/Ni-steel
Type Standard 18--8

12/16/2020 5:54:09 PM

Type corr.concentr.

Sample Name:

Sample ID:

	C	Si	Mn	P	S	Cr	Mo	Ni
	%	%	%	%	%	%	%	%
< x > (1)	0.0224	0.8873	1.1010	0.0263	0.0032	21.6796	3.0718	5.5691

	Al	Co	Cu	Nb	Ti	V	W	Pb
	%	%	%	%	%	%	%	%
< x > (1)	< 0.0005	0.0797	0.1603	< 0.0002	0.0044	0.0893	0.0305	< 0.0002

	Sn	Sb	B	N	Fe			
	%	%	%	%	%			
< x > (1)	0.0092	< 0.0004	0.0024	0.1024	67.1600			

Μαύρο χρώμα SBMποτήριβύσματα-

Model : SBM



MATT BLACK ELECTRO PLATING



MATT BLACK ELECTRO PLATING PROCESS

LOADING TEST FOR SBM

Introduction

MTS Metallurgical Testing Services was engaged to witness the installation of a sample pool fence spigot and to subsequently conduct load tests on the spigot to the requirements of Australian Standard AS1926.1 - 2012.

Standard/Specification AS 1926.1 - 2012, Section 3.2 and Appendix B

Results Summary

(For details of individual tests, refer to the tables on the following pages.)

ID	Item/Heat No.	Dimensions/Type/Details	Finish	Overall Assessment
14117/01	SSRM316	70mm Square, Base Plate 316 Stainless steel	316l	COMPLIES

Remarks

After completion of the testing, the spigot was found to be in sound condition with no breakage, tearing or signs of fracture and no looseness of the fixings.



Colin Cousins
Metallurgical Testing Manager



Accreditation No: 15624
Accredited for compliance
with ISO/IEC 17025

Strength Test

Test Specification AS 1926.1 - 2012, Appendix B Test Procedure MTS-TP3.1 Compression Tests - Products

Specimen ID	Observations	Assessment
14117/01	Test Equipment: Hydraulic ram and 10,000 N load cell Test Load: 330N Load Duration: 45 Secs Deflection under load: 1 mm Permanent Deflection after removal of test load: 0 mm	COMPLIES

Requirements No permanent damage or loosening of fixings.

Γκαλερί έργου για βάση βάσης τετράγωνο γυάλινο βύσμα, SBM-

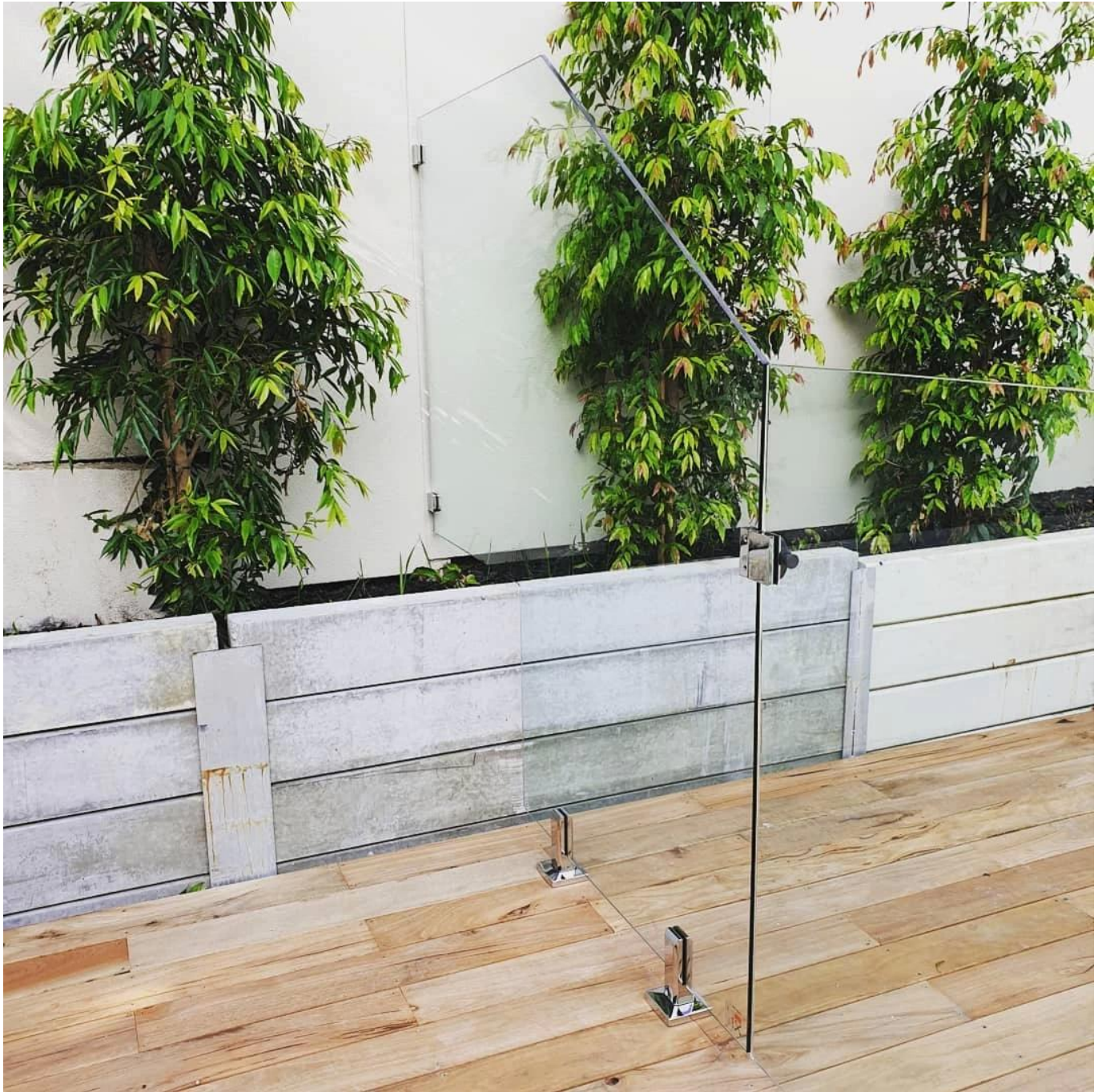



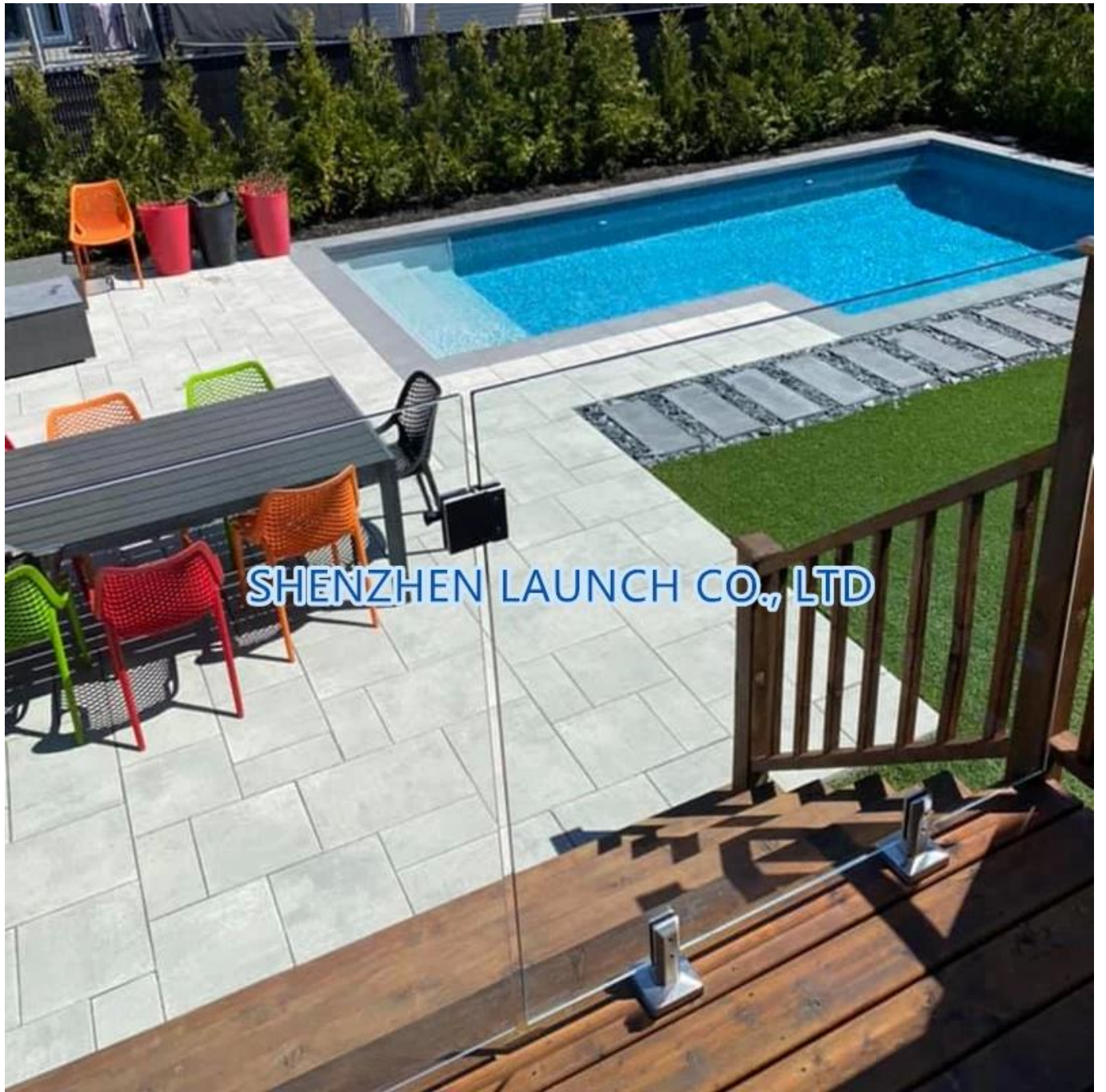



SHENZHEN LAUNCH CO., LTD

