

**Ανοξείδωτο τετράγωνο γυαλί Σφικτήρας φράχτη πσίνας Σφικτήρας φράχτη από ανοξείδωτο χάλυβα
Κήπος Σκαλοπάτια Κάγκελο Μπαλκόνι Γυάλινος σφικτήρας δαπέδου.**

Αριθμός Μοντέλου.	SBM
Βάρος ανά τεμ	1,47 κιλά/σετ
Συσκευασία	1 τεμ σε λευκό κουτί. 12 τμχ σε χαρτοκιβώτιο 365*330*230mm
Υλικό	Duplex 2205 ; SS 316 ; SS 304
Φινίρισμα	Μαύρο , Καθρέφτης , Σατέν
Πάχος γυαλιού	10mm-17,52mm
Αρρυ	γυάλινη πσίνα, γυάλινο κήπο, κιγκλίδωμα, σκάλα και ούτω καθεξής
Διαδικασία παραγωγής	Χύτευση ακριβείας
ΜΟQ	2 τεμ
Χρόνος ανοχής	3 ημέρες - 15 ημέρες

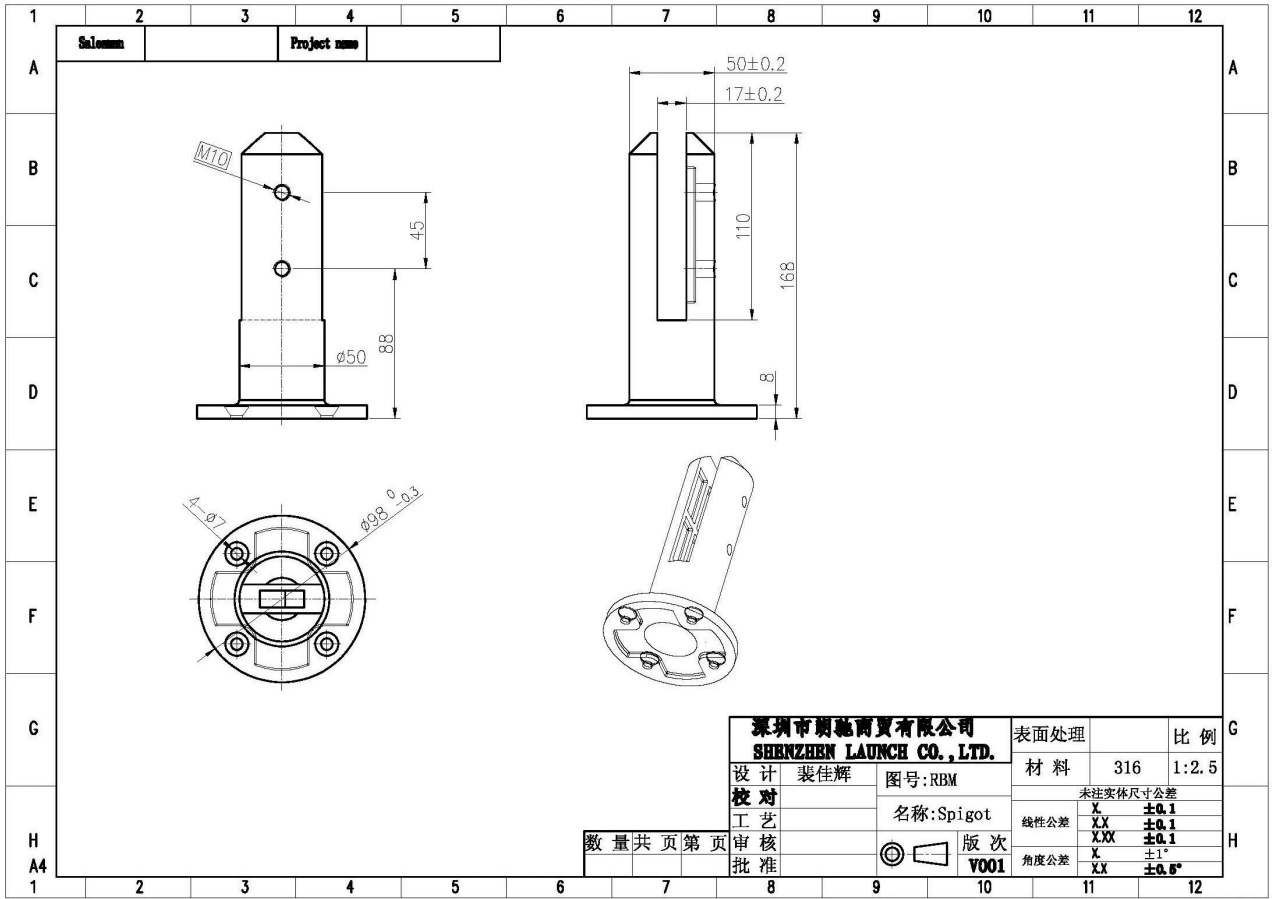



Έκθεση δοκιμής υλικού SS duplex 2205-



12/16/2020 5:54:18 PM

Method: Fe-30
Comment: Cr-, Cr/Ni-steel
Type Standard 18--8

12/16/2020 5:54:09 PM

Type corr.concentr.

Sample Name:

Sample ID:

	C	Si	Mn	P	S	Cr	Mo	Ni
	%	%	%	%	%	%	%	%
< x > (1)	0.0224	0.8873	1.1010	0.0263	0.0032	21.6796	3.0718	5.5691

	Al	Co	Cu	Nb	Ti	V	W	Pb
	%	%	%	%	%	%	%	%
< x > (1)	< 0.0005	0.0797	0.1603	< 0.0002	0.0044	0.0893	0.0305	< 0.0002

	Sn	Sb	B	N	Fe			
	%	%	%	%	%			
< x > (1)	0.0092	< 0.0004	0.0024	0.1024	67.1600			

Οδηγίες τοποθέτησης Ανοξειδωτου τετράγωνου γυάλινου σφιγκτήρα φράχτη πίσινας -



fixing method: base plate spigots

Mark out the centre line of proposed glass fence with a chalk line. Determine clamp location based on a sheet size (recommendation on pages 1 & 2). Use base plate as a template to mark out the hole positions and drill holes to suit.

Note: Do not exceed 100mm gaps between glass panels. Optimum gap is 40mm to 60mm

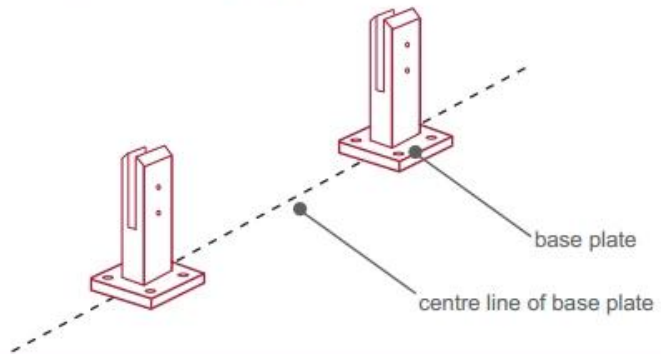

Now the base plated spigots can be fitted to the floor and plumbed via shims (not supplied) under the base plates. Be sure to tighten firmly as the smallest of movement at the base plate will result in noticeable movement at the bottom of the glass fence.

Tip: By setting the two outer spigots of your total span, a string line can be run in the 'throat' of the spigots, giving correct height for all spigots in between

Note: Do not exceed 100mm gap from the fixing surface to the bottom of the glass

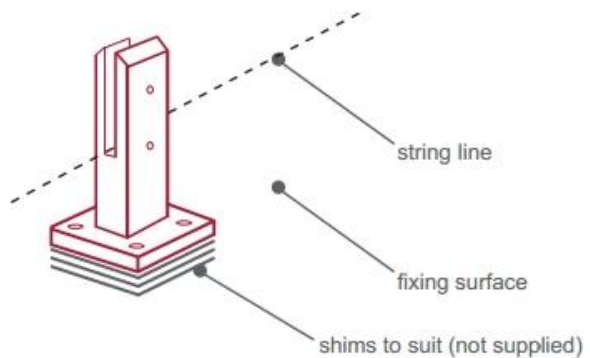

When all spigots are installed, slip domical cover the top of the spigot to hide fixings. It will be necessary to turn the adjustment screws on the spigot face all the way in to allow cover to pass over

Note: Same installation method applies to round base plate spigot

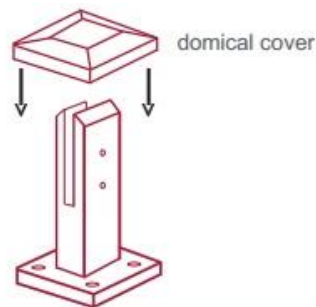

The glass is then installed to the spigots. Place plastic packers between glass & spigot, at no stage should glass touch the metal

How adjustability works:

1. Place glass in spigot
2. Fix/ tension glass both sides with allen key

