

Η εκτόξευση Shenzhen μπορεί να παράγει γυάλινο μεντεσέ με ελατήριο για γυάλινη επένδυση πσίνας, μια γυάλινη μεντεσέ ενός ζεύγους μπορεί να μεταφέρει γυάλινη πύλη 30 κιλών, το πάχος του τοίχου πύλης προτιμά 8-12 mm Εδώ παρουσιάζονται παρακάτω διάφοροι τύποι για την κριτική σας. Καλωσορίστε τα ερωτήματά σας.

Εκθεση Προϊόντος

Τύπος από γυαλί σε γυαλί

Αριθμός Μοντέλου.:G-G

KEBIL 科比奥®



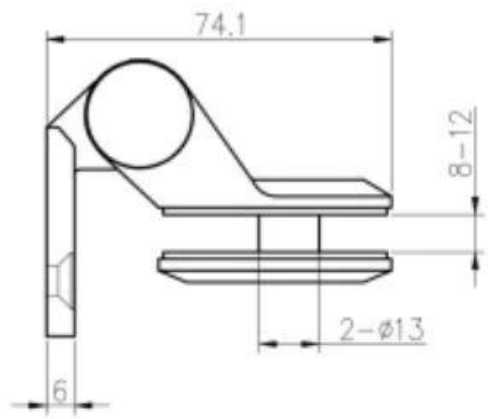
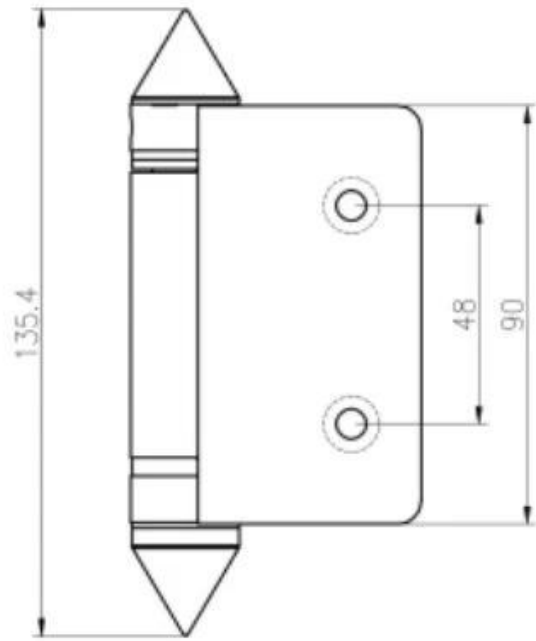
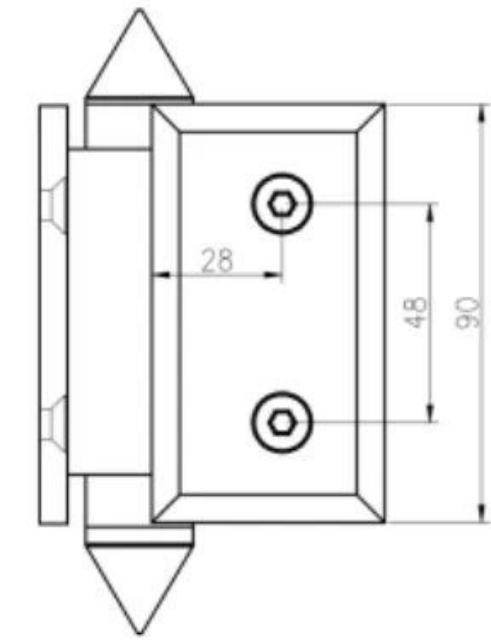

G-W

Instructions for adjusting tension on Glass to Glass hinge

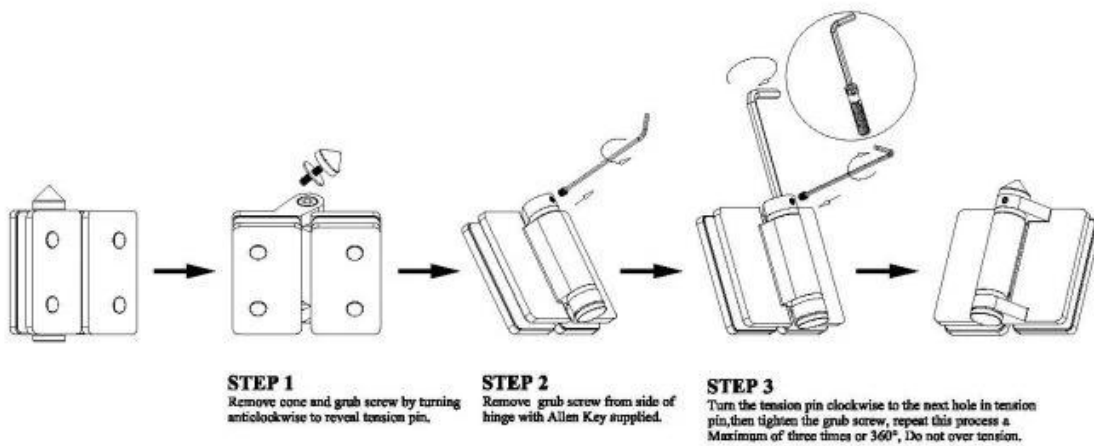

Τύπος γυαλιού σε τοίχο

Αριθμός Μοντέλου.:G-W

KEBIL 科比奥®



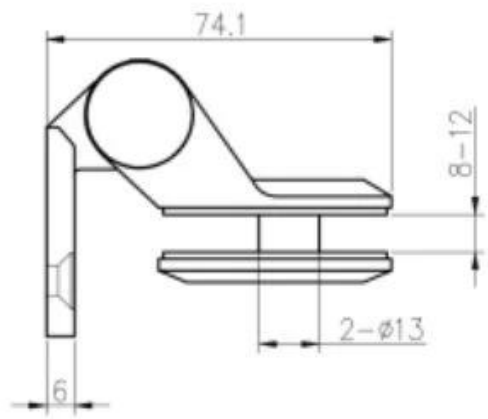
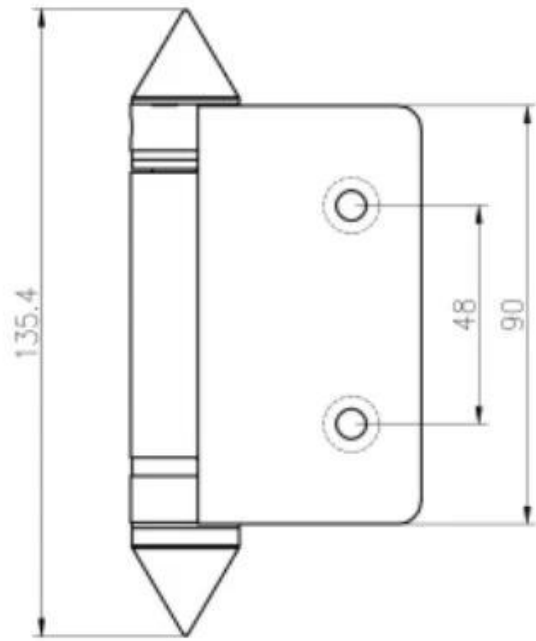
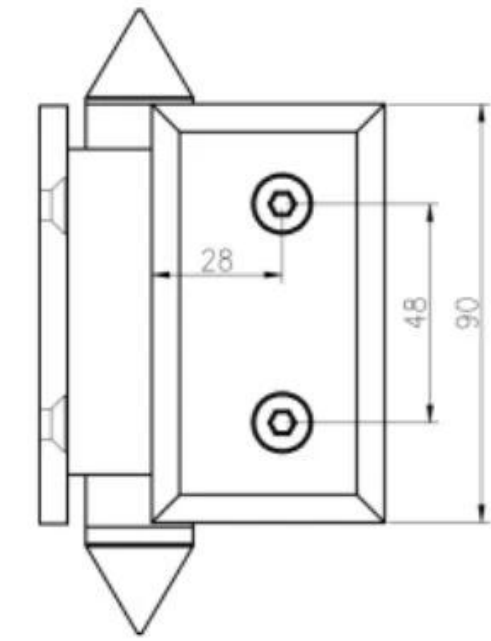

G-W

Instructions for adjusting tension on Glass to Wall hinge

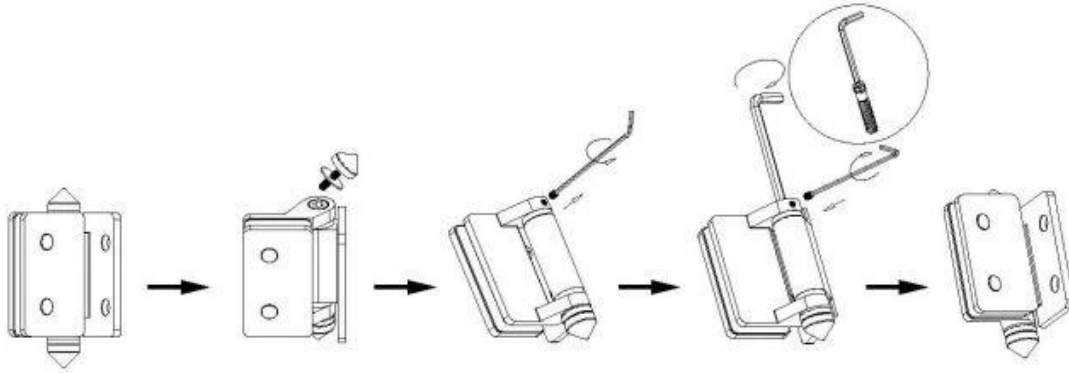

STEP 1

Remove cone and grub screw by turning anticlockwise to reveal tension pin.

STEP 2

Remove grub screw from side of hinge with Allen Key supplied.

STEP 3

Turn the tension pin clockwise to the next hole in tension pin, then tighten the grub screw, repeat this process a Maximum of three times or 360°, Do not over tension.

Γυαλί σε στρογγυλό τύπο

Αριθμός Μοντέλου.:G-R

KEBIL 科比奥®



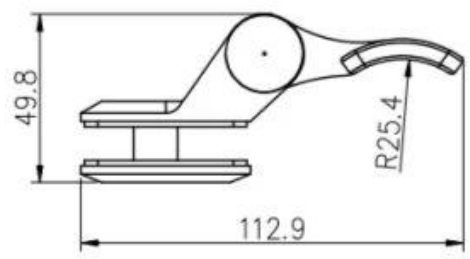
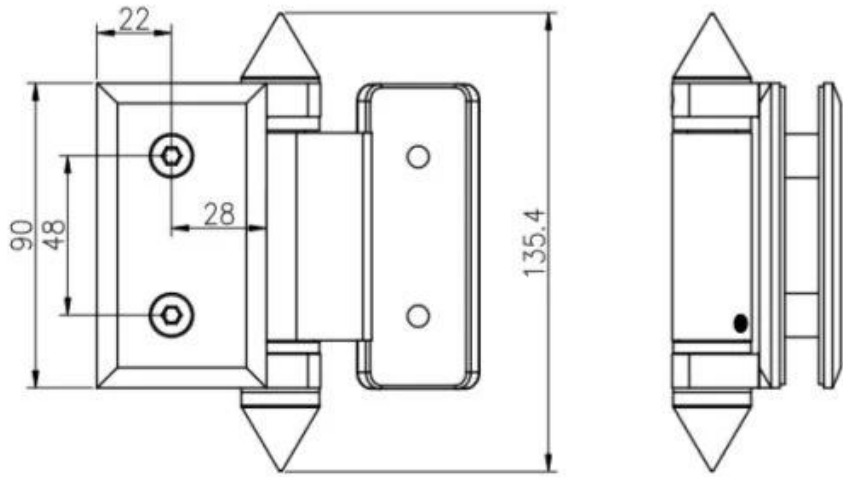

深圳市朗驰商贸有限公司 SHENZHEN LAUNCH CO., LTD.		表面处理	比例
设计	Jacky	材料	1:1.5
校对	图号:G-R	未注实体尺寸公差	
工艺		X	±0.1
审核		XX	±0.1
批准	版次	XXX	±0.1
	V001	X	±1°
		角度公差	XX
			±0.5°



Instructions for adjusting tension on Glass to Round post hinge

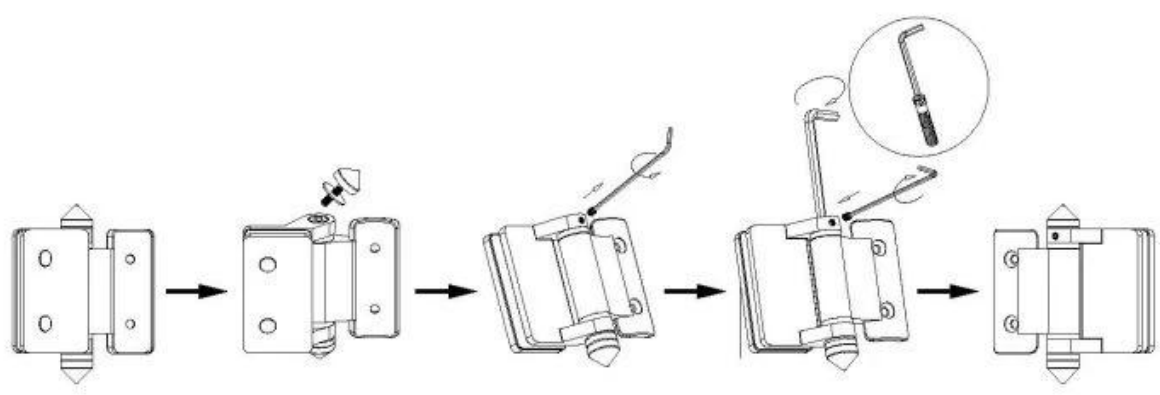

- STEP 1**
Remove cone and grub screw by turning anticlockwise to reveal tension pin.
- STEP 2**
Remove grub screw from side of hinge with Allen Key supplied.
- STEP 3**
Turn the tension pin clockwise to the next hole in tension pin, then tighten the grub screw, repeat this process a Maximum of three times or 360°, Do not over tension.

Μαζική παραγωγή





Συσκευασία Εικονογράφος





Εφαρμογή εικονόγραμμα





Σε περίπτωση που έχετε ενδιαφέροντα, μη διστάσετε να επικοινωνήσετε μαζί μου.

Φρανκ Φανγκ

Τηλέφωνο / Wechat / Whatsapp: +8615906261741

Email: sales02@launch-china.cn