

Πλαίσιο από γυαλί χωρίς πλαίσιο χωρίς πλαίσιο για μπαλκόνι
50mm διάμετρος ποτήρι απόσβεση βίδες τείχος βουνό , αδιάκοπος προβολές !

Το γυάλινο κιγκλίδωμα αποτελείται από ανοξείδωτους βιδωτούς βιδωτούς κοχλίες, υαλοπίνακες με υαλοπίνακες (διαφανές γυαλί πάχους 10-19mm ή εξαιρετικά γυαλί από γυαλί), κορυφαίους χειρολισθήρες προαιρετικά.

Χαρακτηριστικά των βιδών γυαλιού standoff -

- Αριθμός Μοντέλου. SF-50
- Υλικό: ανοξείδωτο ατσάλι 304/316
- βουρτσισμένο ή γυαλισμένο
- 50 * 12 χιλιοστά καπάκι, 50 * 30 χιλιοστά σώμα, M12 * 120 μπουλόνι
- που γίνεται με μηχανική κατεργασία cnc
- στερεά μπουλόνια απομόνωσης
- βάρος 715g
- άλλες διατομές των μπουλονιών standoff διατίθενται επίσης 30mm, 38mm, 40mm κλπ.

φωτογραφίες γυαλιών standoff γυαλιού για μπαλκονόπορτες γυαλί χωρίς πλαίσιο -







SF-50



SF-50

Σχέδιο βιδών γυαλιού χωρίς πλαίσιο χωρίς πλαίσιο -

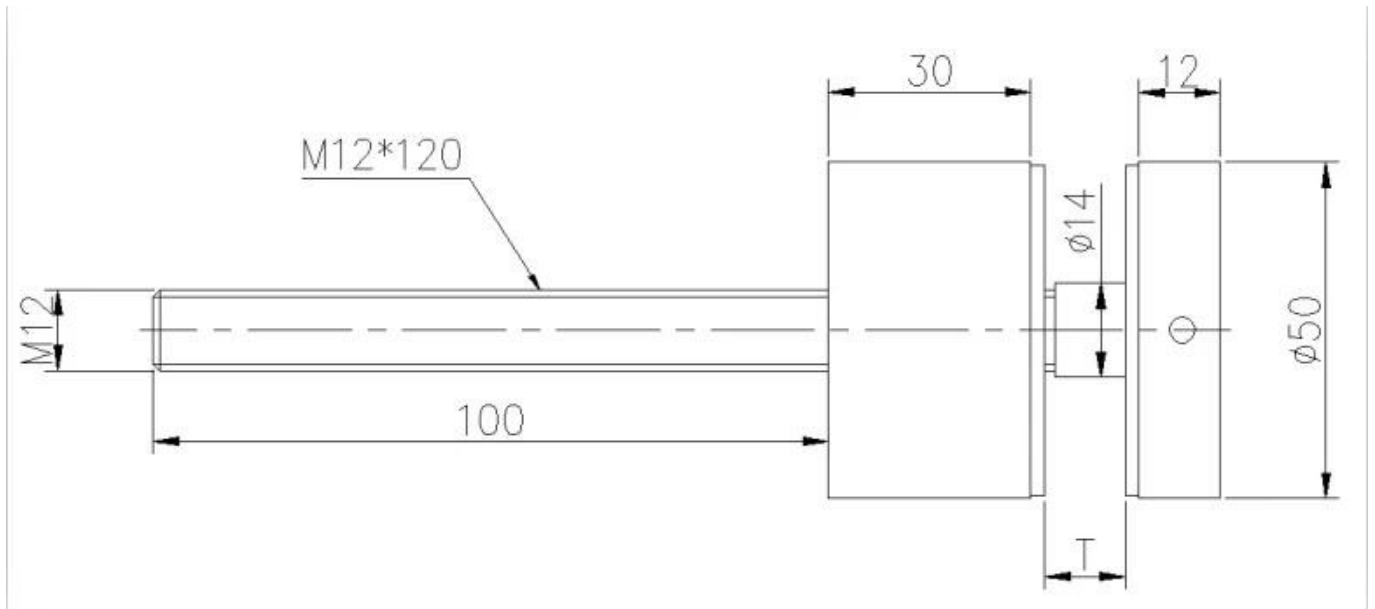

Συσκευασία φωτογραφιών γυαλιού χωρίς πλαίσιο -



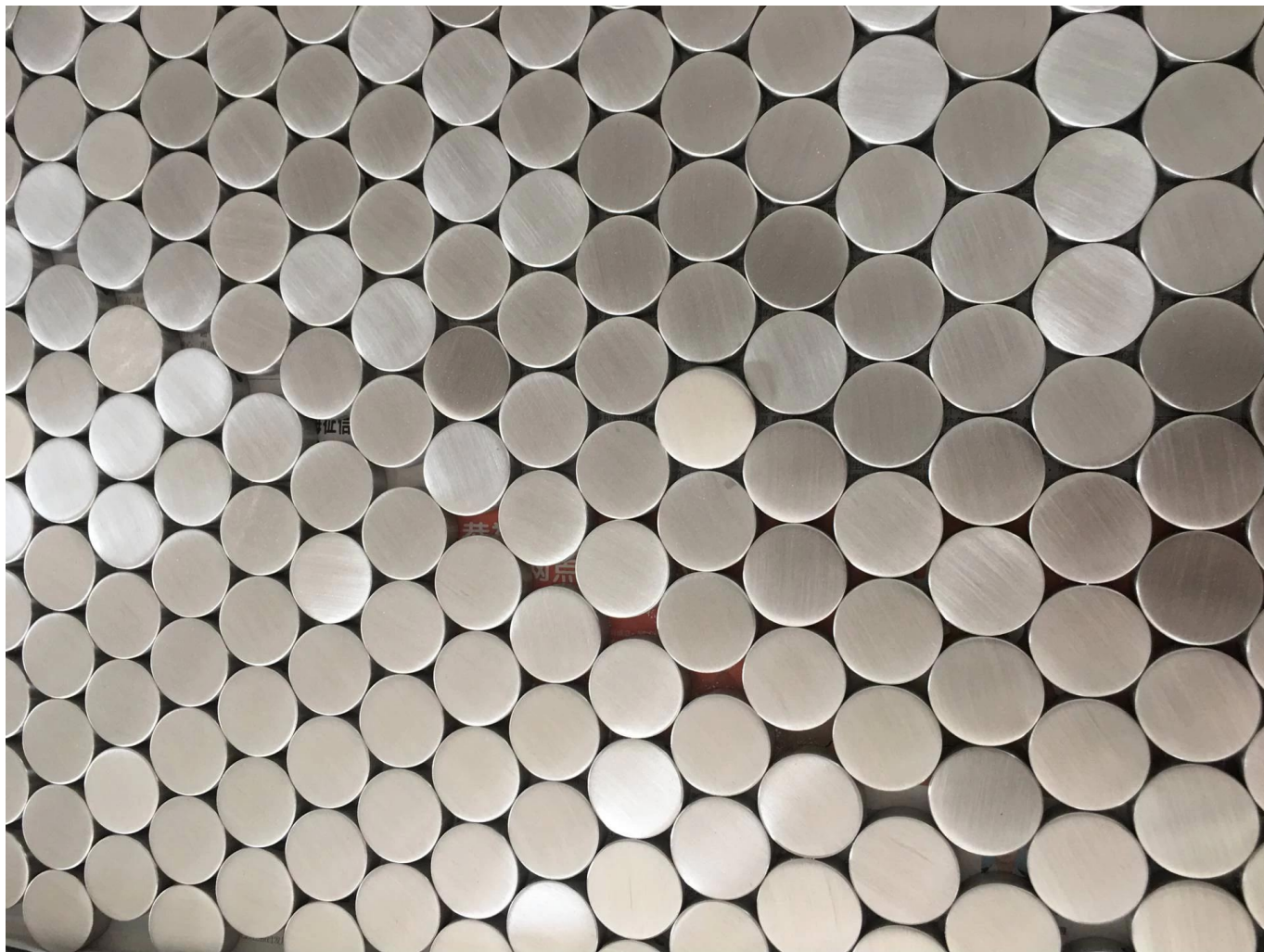



Σχεδιάστε φωτογραφίες γυάλινων κικκλιδωμάτων χωρίς πλαίσιο με τις γυάλινες βίδες μας -





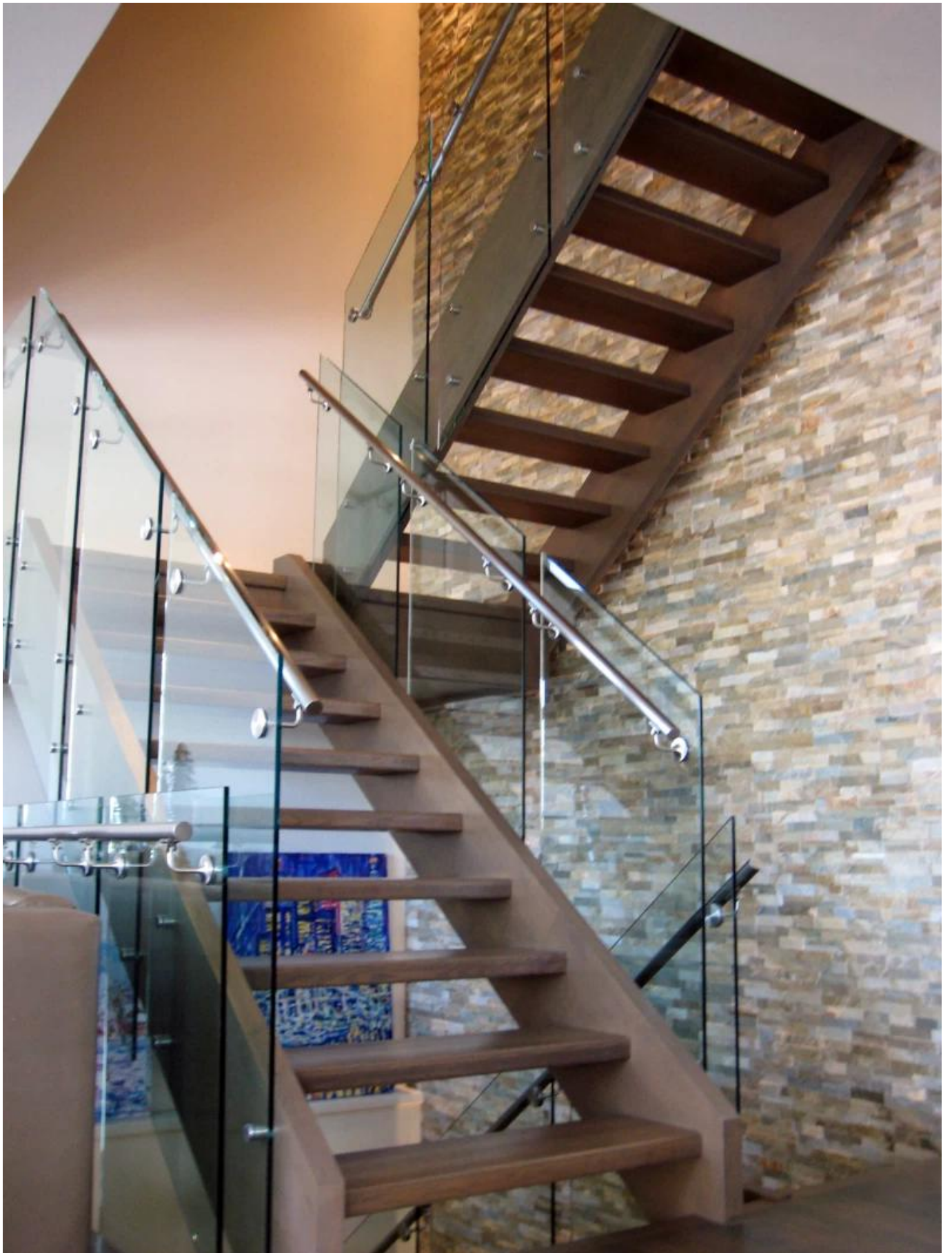





Περισσότερα για την SHENZHEN LAUNCH CO. LTD-

Company profile

Shenzhen Launch Co., Ltd was founded in the year 2004, with full experience in below production lines:

1. Construction materials including stainless steel railing materials , handrail fittings ,clamps, brackets, flanges , stainless steel tubing /sheet etc.
2. Professional OEM services such as laser cutting, precision casting (Stainless steel and Titanium), metal punch, cold rolling precision tube (tolerance for inner and outer diameter can be controlled within plus/minus0.01mm), CNC machining, Al, Zinc alloy die casting, hardware welding, tube bending, water heater accessories, solar energy equipment accessories, auto parts, etc.

We have been supplying middle and high end construction materials / OEM fabrication parts to our main market in Europe , North America , Oceania , for more than 15 years . Recent years we have also been supplying our materials to Middle East , South America .



Laser cutting workshop



CNC machine workshop



Sheet metal & bending machine workshop



Stamping shop



160T 宽台面冲床 模具加工尺寸800*1800mm



Die making shop



Sample Show room



Project reference- Hot dip galvanizing parts for USA





Welding handrails for Australia



SS Front panel project for building in Australia



SS sheet panels



Steel tubing for USA



SS HANDRAIL FOR CANADA



Office address: B5-003, 5/F-Block 3, Yilida Building, No. 1092 Nanshan Road, Nanshan District, Shenzhen, China, postal code 518054

Tel: 86-755-86037559 Fax:86-755-86372611

Factory address in Dongguan : 1st floor, Building A, Ruixin Hengye No.3 industrial area, Taixing Road, Shigu Town, Tangxia district, Dongguan

Contacts:

Gao Binfeng –Managing director E. admin@launch-china.cn PH. 86-755-86037559

Celia Chen – Sales manager E. sales01@launch-china.cn PH. 86-755-86037559 MOB .+8613590273543

Jacky Pei – Chief Engineer PH . 86-755-86037559

