

Balkon hek vloer glas montagebeugels duplex 2205 materiaal voor buitengebruik voor 1/2 "dikke glazen leuningen.

1. Kenmerken van balkon hek vloer glas montagebeugels-

Materiaal	Duplex 2205
Af hebben	satijn geborsteld
Hoogte	168 mm
Glasdikte	10-13.52mm dikte glas
Hoogte	168 mm; of kan worden aangepast
Plastic pakking	Gemaakt van nylon materiaal, het kan duren voor een levenslange tijd
Betonnen bout om te passen	M8 * 100
Eenheid gewicht per pc	1.42kg
Op voorraad	Ja
Moq	2 stuks

2. Dimensies van SBM Glazen montagebeugels-

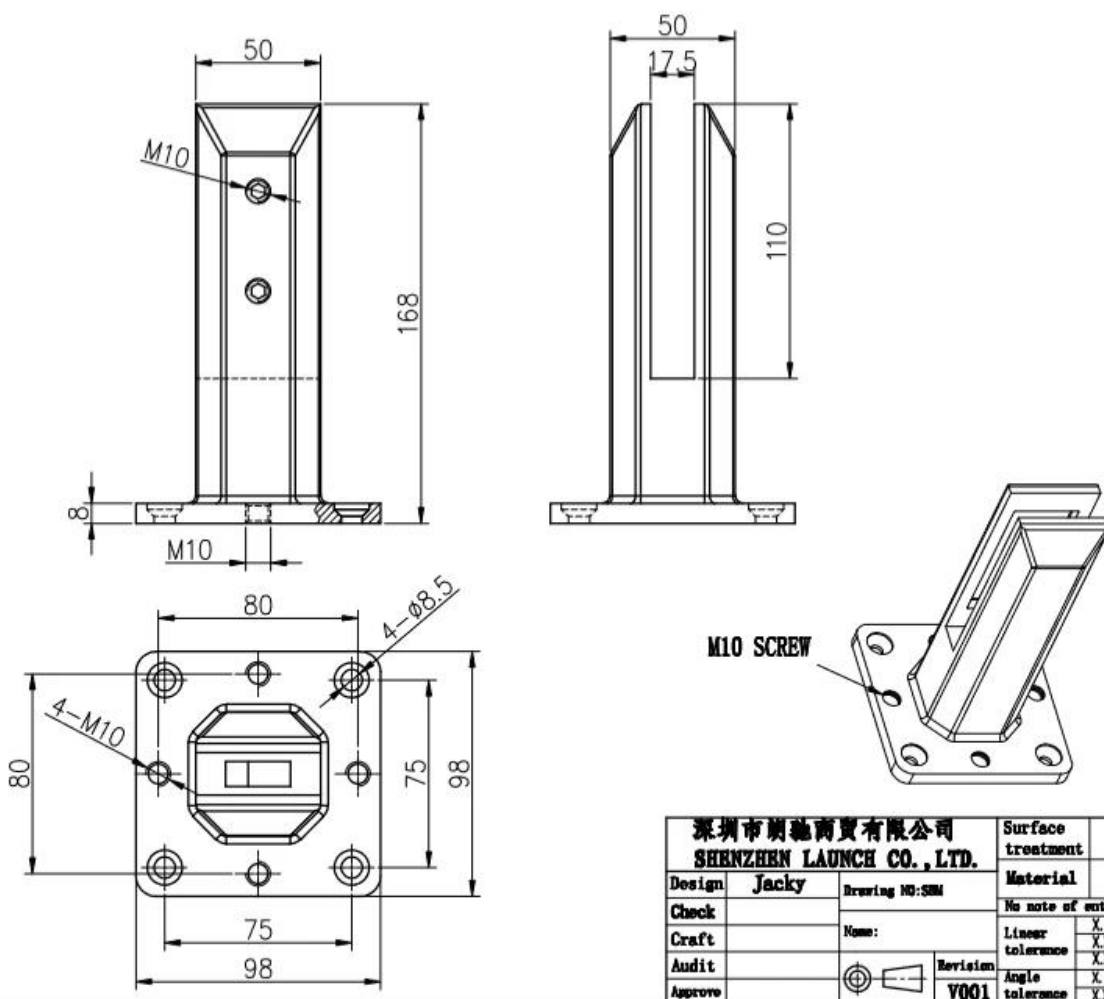

深圳市朗驰商贸有限公司 SHENZHEN LAUNCH CO., LTD.		Surface treatment	Preparation
Design	Jacky	Material	1:2
Check	Drawing NO: SBM	No note of entity size tolerance	
Craft	Name:	Linear tolerance	X ±0.1
Audit		tolerance	XX ±0.1
Approve	Revision	Angle tolerance	X ±1°
	V001		XX ±0.5°

3.Bezig met ladentest&MateriaaltestvoorSBMGlazen montagebeugels-



LOADING TEST FOR SBM

Introduction

MTS Metallurgical Testing Services was engaged to witness the installation of a sample pool fence spigot and to subsequently conduct load tests on the spigot to the requirements of Australian Standard AS1926.1 - 2012.

Standard/Specification AS 1926.1 - 2012, Section 3.2 and Appendix B

Results Summary

(For details of individual tests, refer to the tables on the following pages.)

ID	Item/Heat No.	Dimensions/Type/Details	Finish	Overall Assessment
14117/01	SSRM316	60mm Square, Base Plate 316 Stainless steel	316I	COMPLIES

Remarks

After completion of the testing, the spigot was found to be in sound condition with no breakage, tearing or signs of fracture and no looseness of the fixings.

Colin Cousins
Metallurgical Testing Manager



Accreditation No: 15624
Accredited for compliance
with ISO/IEC 17025

Strength Test

Test Specification AS 1926.1 - 2012, Appendix B Test Procedure MTS-TP3.1 Compression Tests - Products

Specimen ID	Observations	Assessment
14117/01	Test Equipment: Hydraulic ram and 10,000 N load cell Test Load: 330N Load Duration: 45 Secs Deflection under load: 1 mm Permanent Deflection after removal of test load: 0 mm	COMPLIES

Requirements No permanent damage or loosening of fixings.



12/16/2020 5:54:18 PM

Method: Fe-30
 Comment: Cr-, Cr/Ni-steel
 Type Standard 18--8

12/16/2020 5:54:09 PM

Type corr.concentr.

Sample Name:

Sample ID:

	C	Si	Mn	P	S	Cr	Mo	Ni
	%	%	%	%	%	%	%	%
< x > (1)	0.0224	0.8873	1.1010	0.0263	0.0032	21.6796	3.0718	5.5691

	Al	Co	Cu	Nb	Ti	V	W	Pb
	%	%	%	%	%	%	%	%
< x > (1)	< 0.0005	0.0797	0.1603	< 0.0002	0.0044	0.0893	0.0305	< 0.0002

	Sn	Sb	B	N	Fe			
	%	%	%	%	%			
< x > (1)	0.0092	< 0.0004	0.0024	0.1024	67.1600			

4. Installatie Instructies voor SBM Glazen montagebeugels



fixing method: base plate spigots

Mark out the centre line of proposed glass fence with a chalk line. Determine clamp location based on a sheet size (recommendation on pages 1 & 2). Use base plate as a template to mark out the hole positions and drill holes to suit.

Note: Do not exceed 100mm gaps between glass panels. Optimum gap is 40mm to 60mm

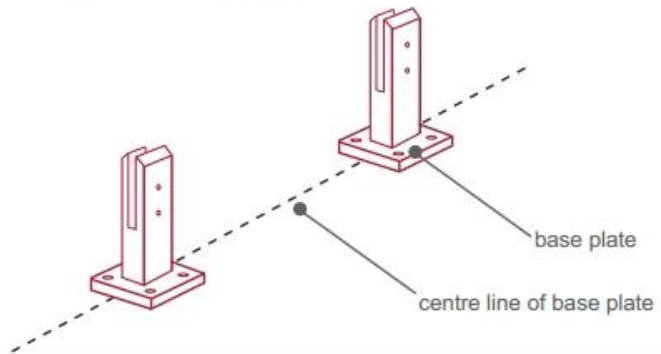

Now the base plated spigots can be fitted to the floor and plumbed via shims (not supplied) under the base plates. Be sure to tighten firmly as the smallest of movement at the base plate will result in noticeable movement at the bottom of the glass fence.

Tip: By setting the two outer spigots of your total span, a string line can be run in the 'throat' of the spigots, giving correct height for all spigots in between

Note: Do not exceed 100mm gap from the fixing surface to the bottom of the glass

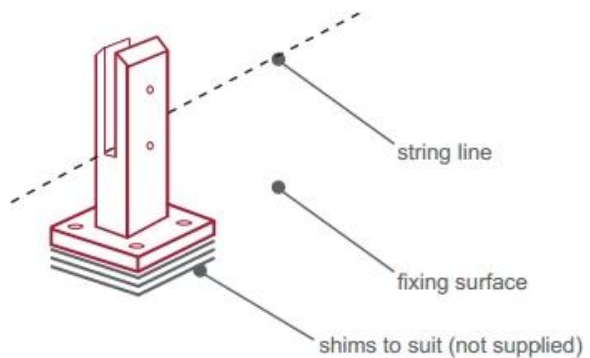

When all spigots are installed, slip domical cover the top of the spigot to hide fixings. It will be necessary to turn the adjustment screws on the spigot face all the way in to allow cover to pass over

Note: Same installation method applies to round base plate spigot

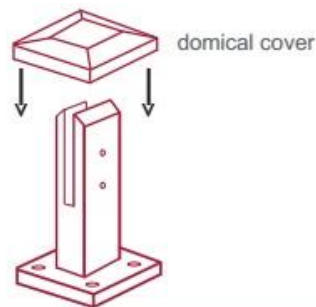

The glass is then installed to the spigots. Place plastic packers between glass & spigot, at no stage should glass touch the metal

How adjustability works:

1. Place glass in spigot
2. Fix/ tension glass both sides with allen key

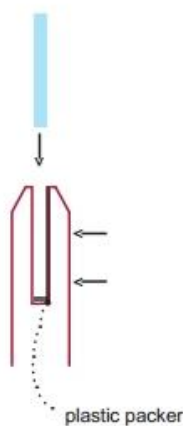

5.InpakkendetailsvoorSBMGlazen montagebeugels-

1 stuk in een witte doos; 12 stuks in een doos-



6.MassaProductieWerkwijzevoorSBMGlazen montagebeugels-

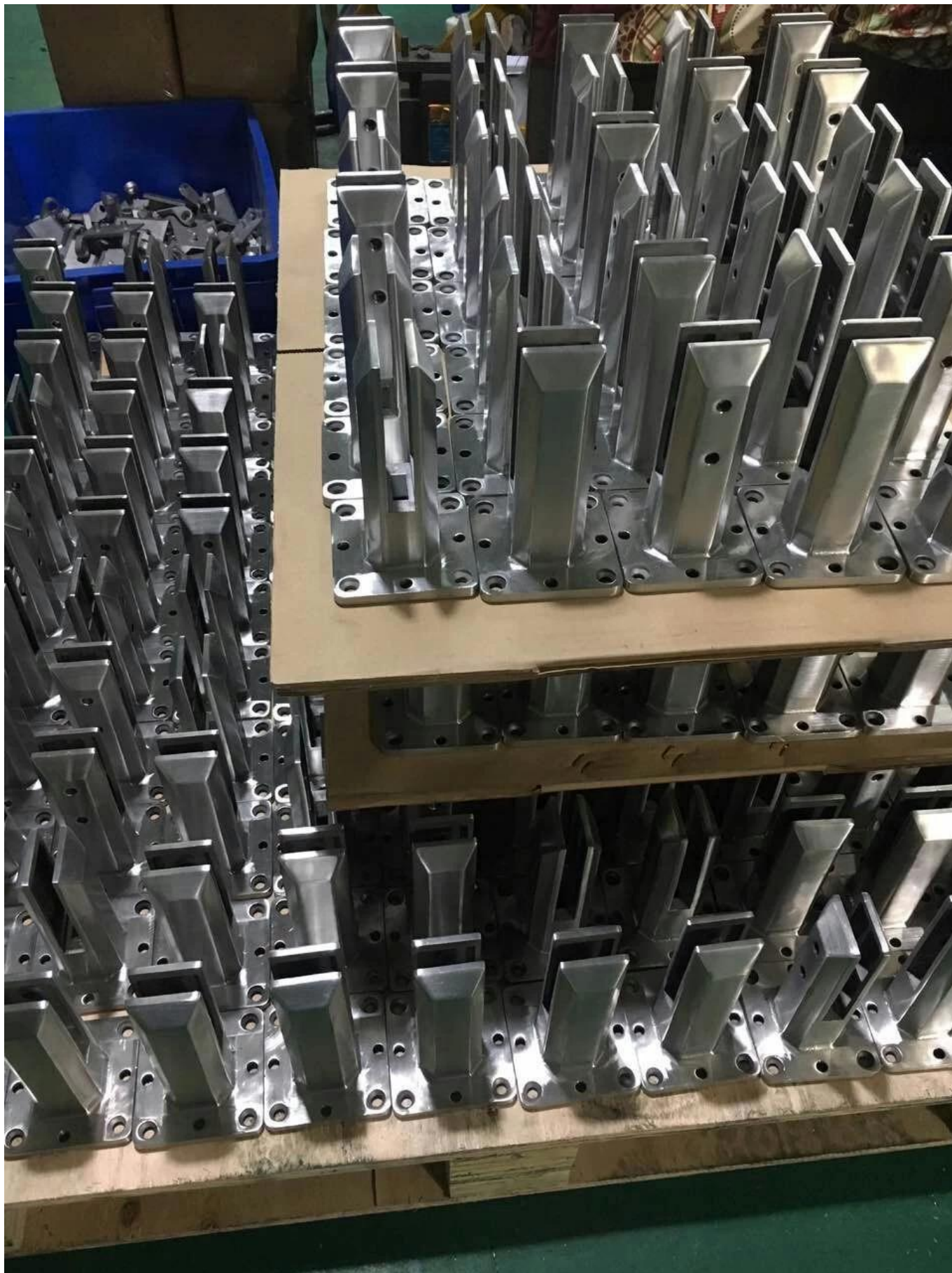



7.Meermodellenvanglasspievoorjouwselectie-



Glass spigot



MODEL # SBM



MODEL # SCM



MODEL # RBM



MODEL # RCM

8. ProjectFoto'svanZachtGlasLeuningenmetglasspigots-







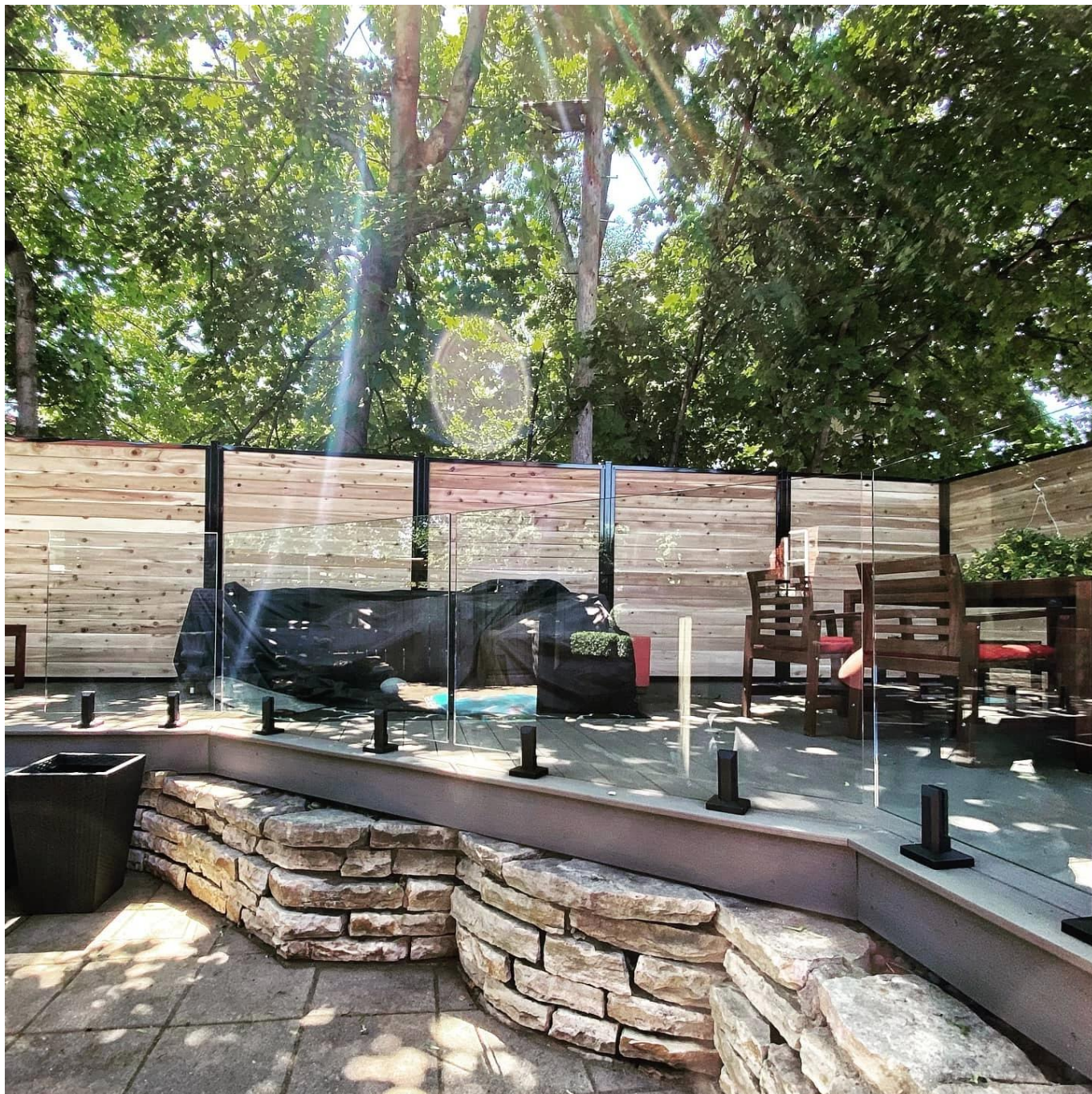

We hebben ook glazen scharnier en magnetische grendels en glasklemmen en gehard glas om te gaan met het hele frame-loze glazen railsysteem.

Neem gerust contact met ons op om offertes te krijgen!

Shenzhen Launch Co., Ltd

Geverifieerd door SGS, Rapportnummer 19536352_P + T

Kantoor Toevoegen:

B5-003, 5 / F-blok 3, Yilida-gebouw, No. 1092 Nanshan Road, Nanshan District, Shenzhen, China, Postcode 518054

TEL: 86-755-86037559 FAX: 86-755-86372611

MOB (WhatsApp, Wechat, Viber) +86 135 9027 3543

Contact:CeliaChen