

Marine Grade Stainless Steel Duplex 2205 Base mount Square glass spigot Australian standard for frameless glass fence .

Features -

- Model No. SBM
- Material - duplex 2205 , SS 316, SS316L , SS304
- Finish- satin ,mirror , black , gold , white etc.
- Height 168mm
- Base cover , plastic insert , adjustable screws included
- 1 pc packed into a white box ; 12 pcs into a carton

Photo Galleries -

**KEBIL** 科比奥®



**KEBIL** 科比奥®







Drawing-

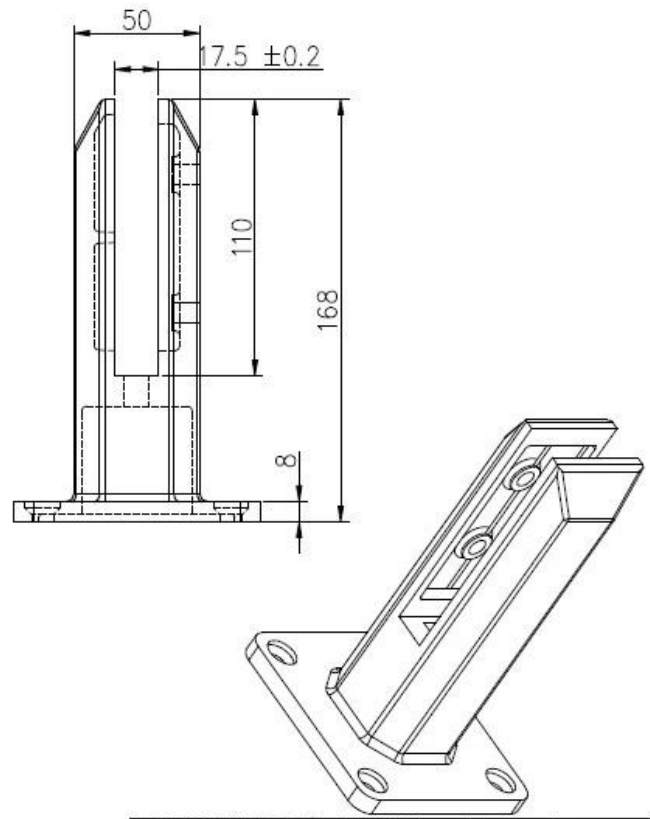
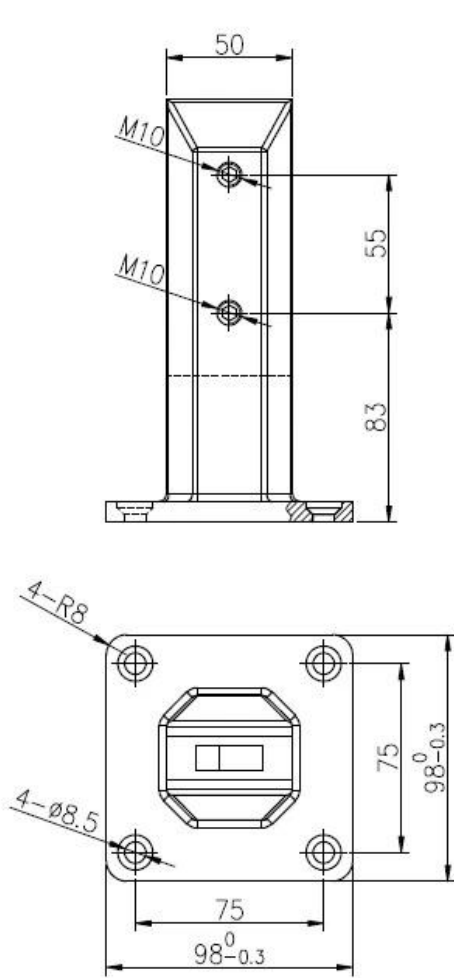

深圳市朗馳商貿有限公司 <b>SHENZHEN LAUNCH CO., LTD.</b>		Surface treatment		Proportio
Design	Jacky	Material	2205	1:1
Check		No note of entity size tolerance		
Craft		Linear tolerance	X.X	±0.1
Audit		Revision	X.XX	±0.1
		Angle	X	±1°

Duplex 2205 material test report-



12/16/2020 5:54:18 PM

Method: Fe-30  
 Comment: Cr-, Cr/Ni-steel  
 Type Standard 18--8

Type corr.concentr.

12/16/2020 5:54:09 PM

Sample Name: Sample ID:

	C	Si	Mn	P	S	Cr	Mo	Ni
	%	%	%	%	%	%	%	%
< x > (1)	0.0224	0.8873	1.1010	0.0263	0.0032	21.6796	3.0718	5.5691

	Al	Co	Cu	Nb	Ti	V	W	Pb
	%	%	%	%	%	%	%	%
< x > (1)	< 0.0005	0.0797	0.1603	< 0.0002	0.0044	0.0893	0.0305	< 0.0002

	Sn	Sb	B	N	Fe			
	%	%	%	%	%			
< x > (1)	0.0092	< 0.0004	0.0024	0.1024	67.1600			

Black color SBM glass spigots-

**Model : SBM**



MATT BLACK ELECTRO PLATING



MATT BLACK ELECTRO PLATING PROCESS



# LOADING TEST FOR SBM

## Introduction

MTS Metallurgical Testing Services was engaged to witness the installation of a sample pool fence spigot and to subsequently conduct load tests on the spigot to the requirements of Australian Standard AS1926.1 - 2012.

Standard/Specification AS 1926.1 - 2012, Section 3.2 and Appendix B

## Results Summary

(For details of individual tests, refer to the tables on the following pages.)

ID	Item/Heat No.	Dimensions/Type/Details	Finish	Overall Assessment
14117/01	SSRM316	70mm Square, Base Plate 316 Stainless steel	316l	COMPLIES

## Remarks

After completion of the testing, the spigot was found to be in sound condition with no breakage, tearing or signs of fracture and no looseness of the fixings.



Colin Cousins  
Metallurgical Testing Manager



Accreditation No: 15624  
Accredited for compliance  
with ISO/IEC 17025

## Strength Test

Test Specification AS 1926.1 - 2012, Appendix B Test Procedure MTS-TP3.1 Compression Tests - Products

Specimen ID	Observations	Assessment
14117/01	Test Equipment: Hydraulic ram and 10,000 N load cell Test Load: 330N Load Duration: 45 Secs Deflection under load: 1 mm Permanent Deflection after removal of test load: 0 mm	COMPLIES

Requirements No permanent damage or loosening of fixings.

Project galleries for base mount square glass spigot , SBM-

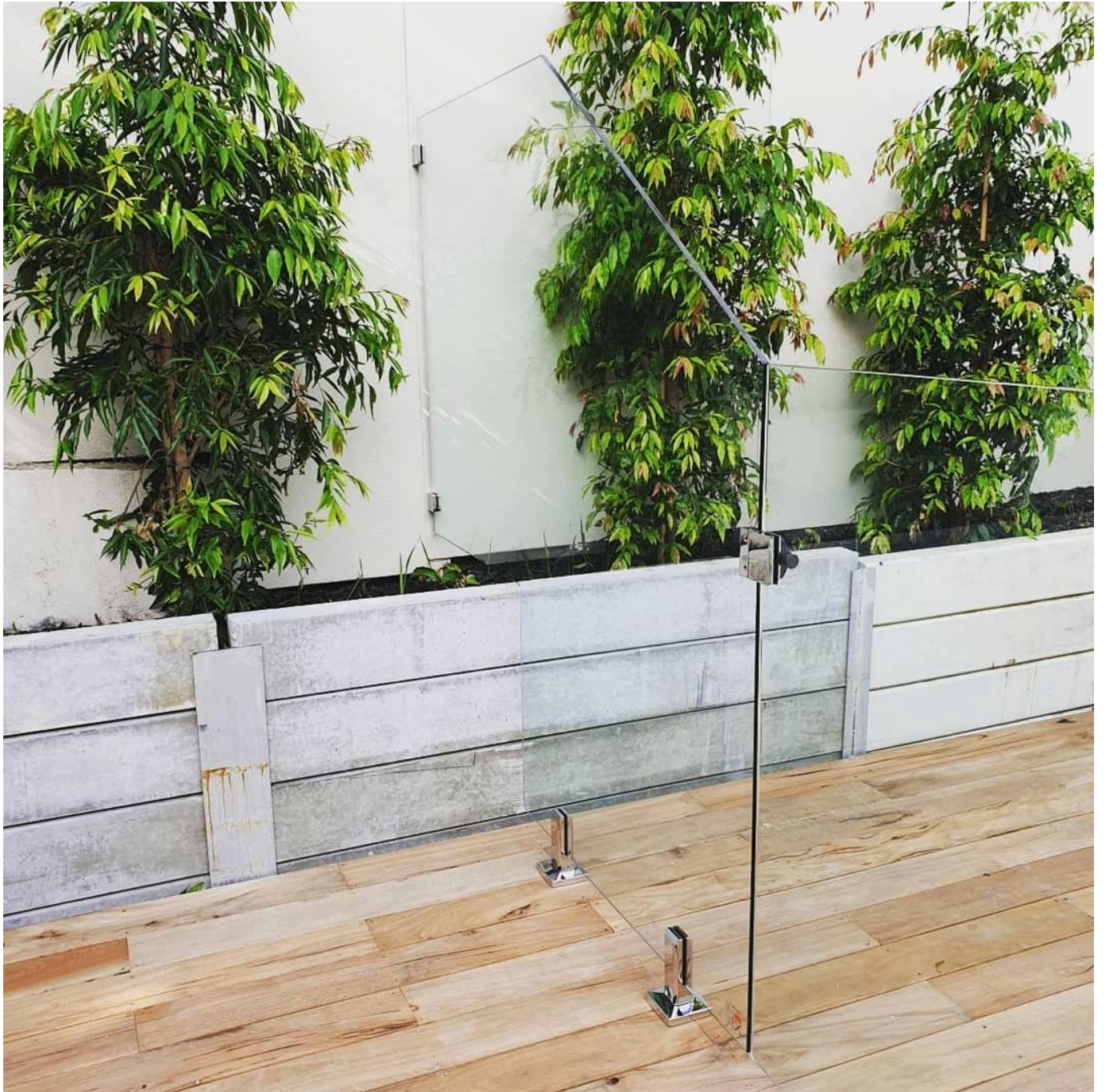



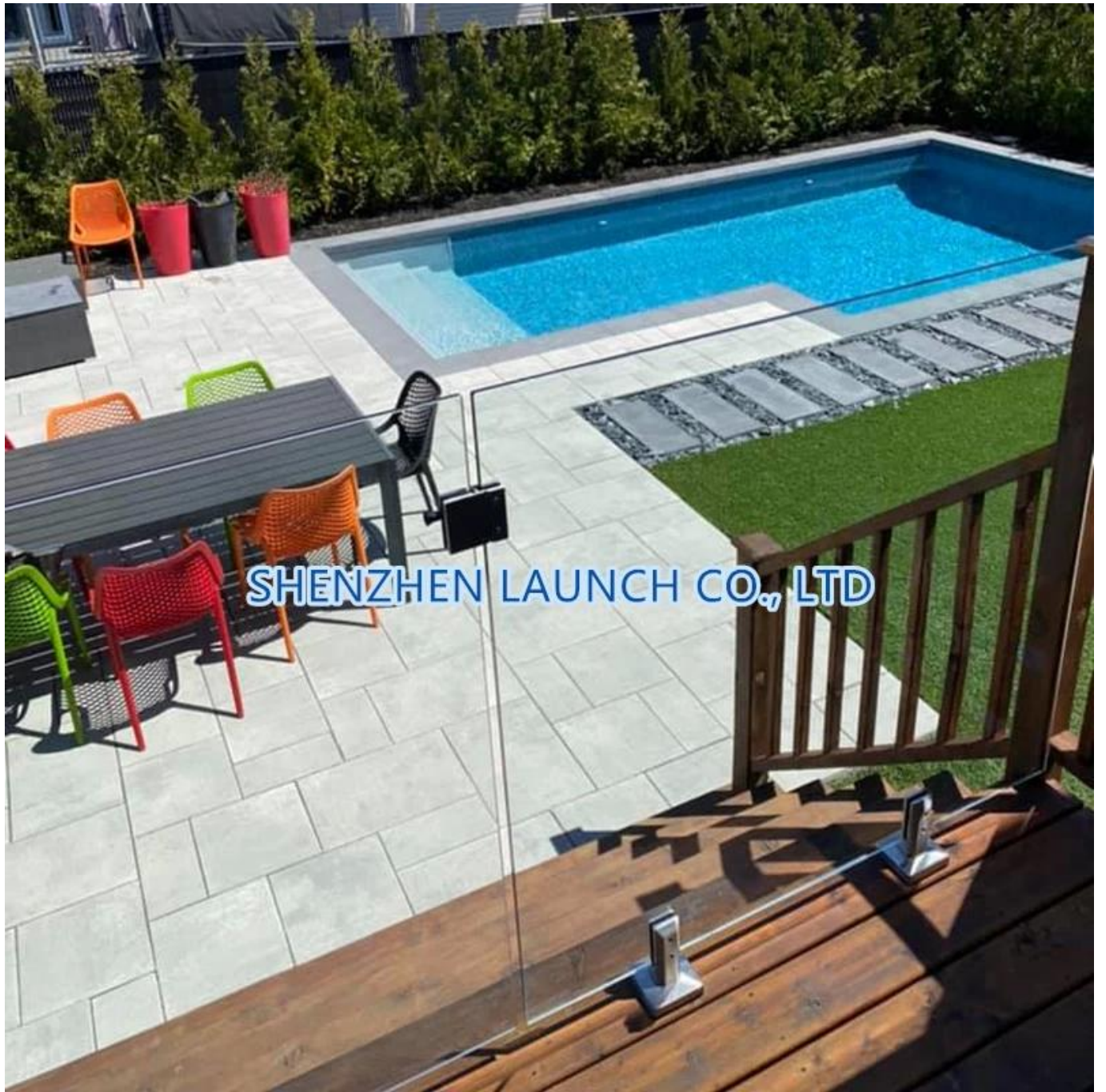

SHENZHEN LAUNCH CO., LTD



SHENZHEN LAUNCH CO., LTD



SHENZHEN LAUNCH CO., LTD