

Stainless Steel Black Glass Spigot For Frameless Glass Railing Pool Fence Railing

Product Description - black glass spigot

Product Name	Stainless Steel Black Glass Spigot For Frameless Glass Railing Pool Fence Railing
Material	Duplex 2205 / stainless steel 316
Standard	Australian Standard AS 1926.1-2012 : Safety Barriers for Swimming Pools
Installation	4 x 11mm Counter Sunk Holes for timber screw or Countersunk bolt installation
Finish	Mirror polished / satin brushed / black / gold
For Glass Thickness	8-13.52mm (NO hole required in glass)
Height	168mm
Base Cover Size	100x100mm for square, diameter 100mm for round
Mounting	Surface/floor mounting
Manufacture Method	Casting (high quality)
Packaging Details	1) One piece into one bubble bag, then into one white box 2) 12 pieces into 365x330x230mm cardboard carton 3) Packing as customers' requirements
Application	Pool fence/balcony/deck/stairs glass railing
Factory Inspection	Available
Sample	Available
MOQ	10 pieces. Could order as per your job requirement.
OEM & ODM Service	Available

Product Photos - black glass spigot

1) black electroplated - glossy



2) black electroplated - matte

KEBIL 科比奥®



3) black powder coating

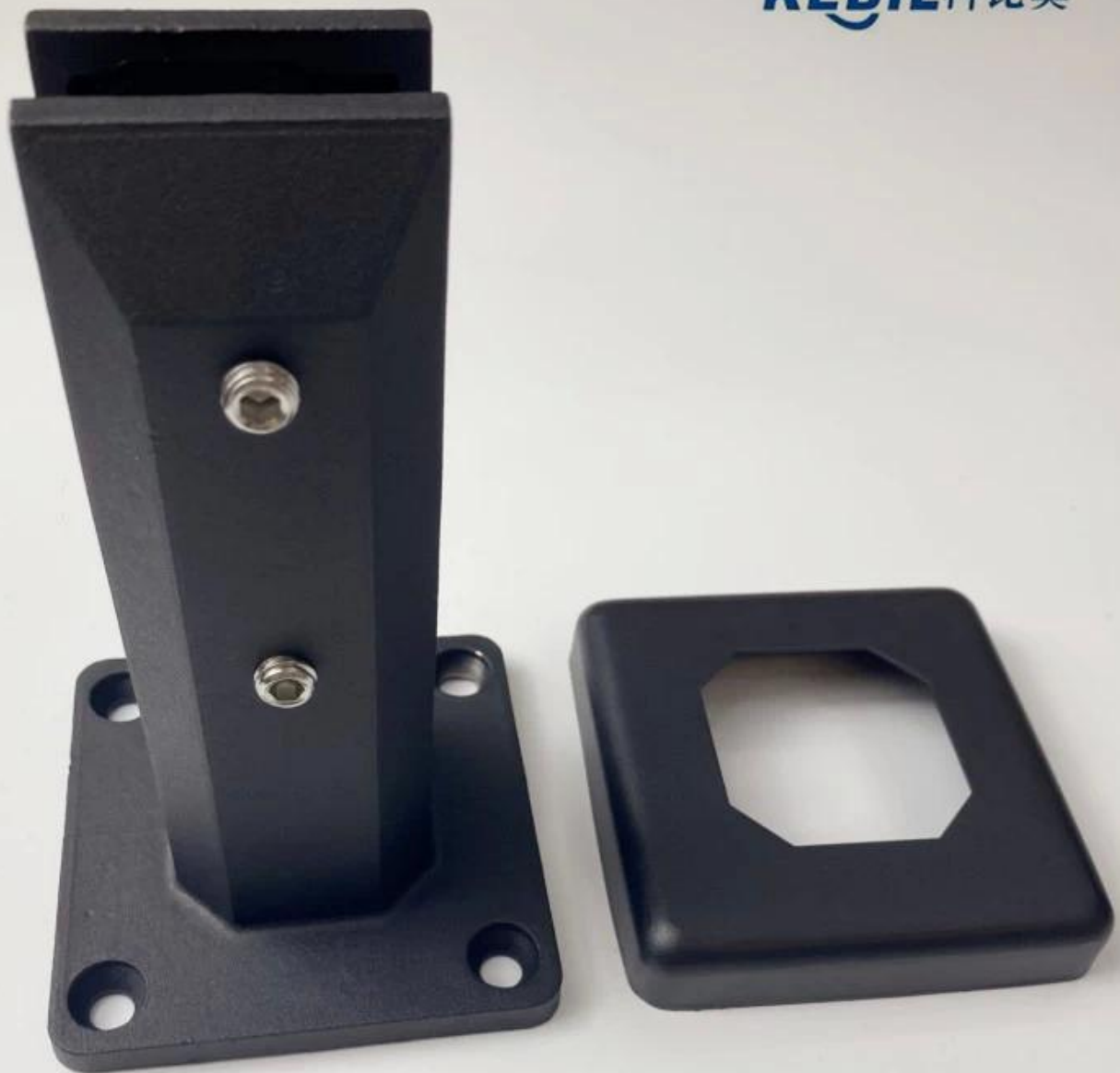

Technical Drawing - black glass spigot

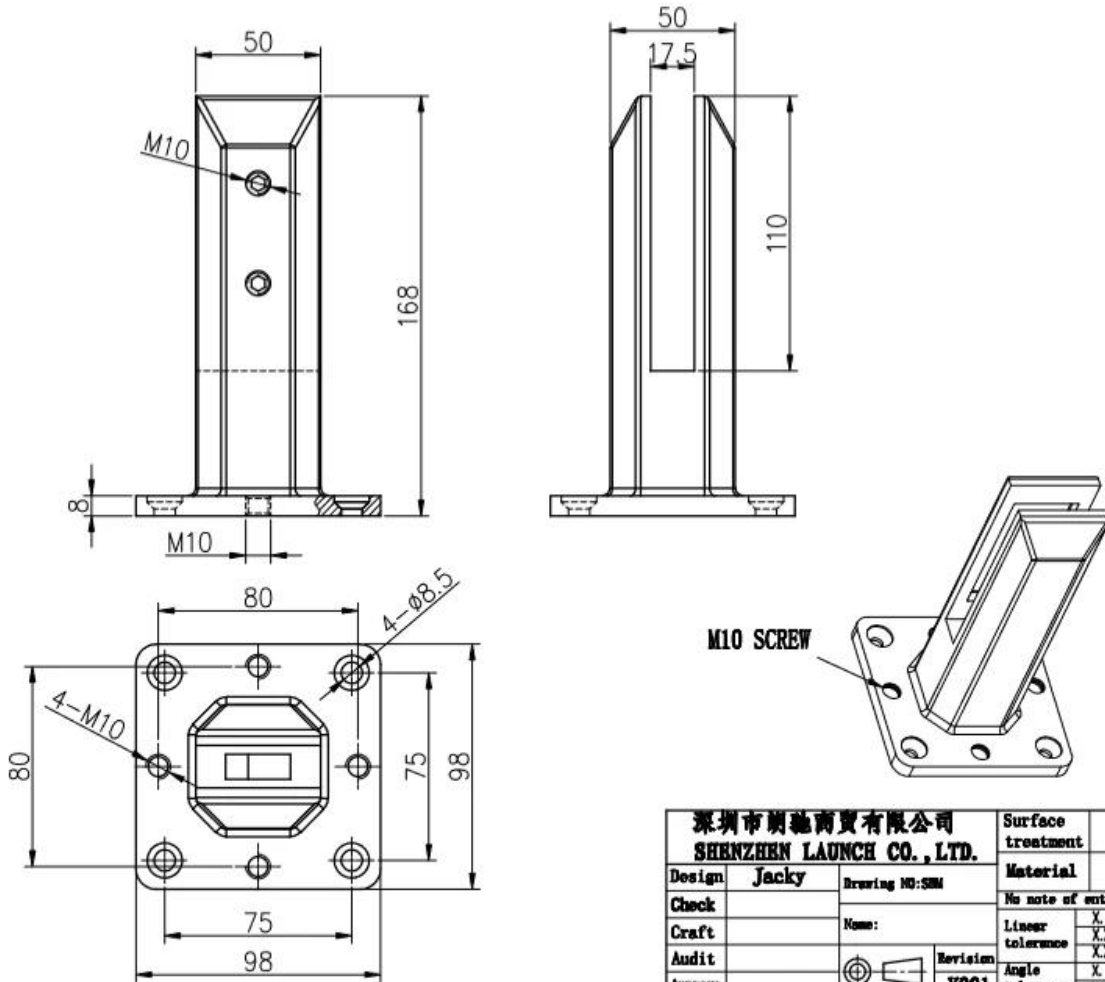

Production Packing Information - black glass spigot





Installation Guideline - black glass spigot



fixing method: base plate spigots

Mark out the centre line of proposed glass fence with a chalk line. Determine clamp location based on a sheet size (recommendation on pages 1 & 2). Use base plate as a template to mark out the hole positions and drill holes to suit.

Note: Do not exceed 100mm gaps between glass panels. Optimum gap is 40mm to 60mm

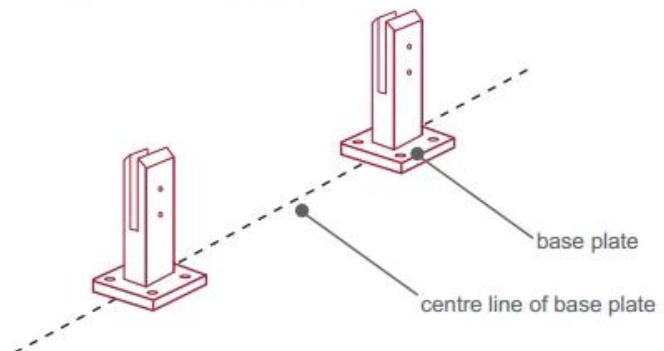

Now the base plated spigots can be fitted to the floor and plumbed via shims (not supplied) under the base plates. Be sure to tighten firmly as the smallest of movement at the base plate will result in noticeable movement at the bottom of the glass fence.

Tip: By setting the two outer spigots of your total span, a string line can be run in the 'throat' of the spigots, giving correct height for all spigots in between

Note: Do not exceed 100mm gap from the fixing surface to the bottom of the glass

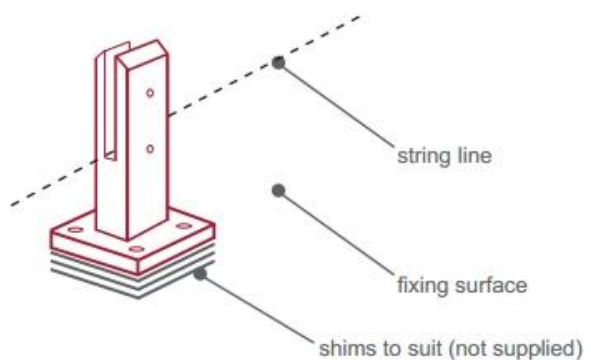

When all spigots are installed, slip domical cover the top of the spigot to hide fixings. It will be necessary to turn the adjustment screws on the spigot face all the way in to allow cover to pass over

Note: Same installation method applies to round base plate spigot

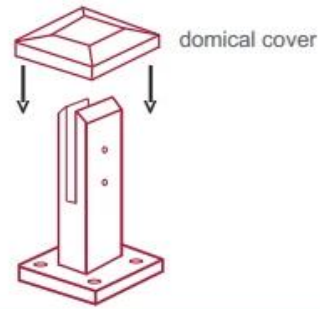

The glass is then installed to the spigots. Place plastic packers between glass & spigot, at no stage should glass touch the metal

How adjustability works:

1. Place glass in spigot
2. Fix/ tension glass both sides with allen key

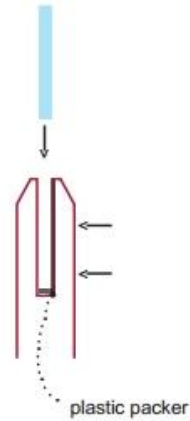

Project Photos - black glass spigot



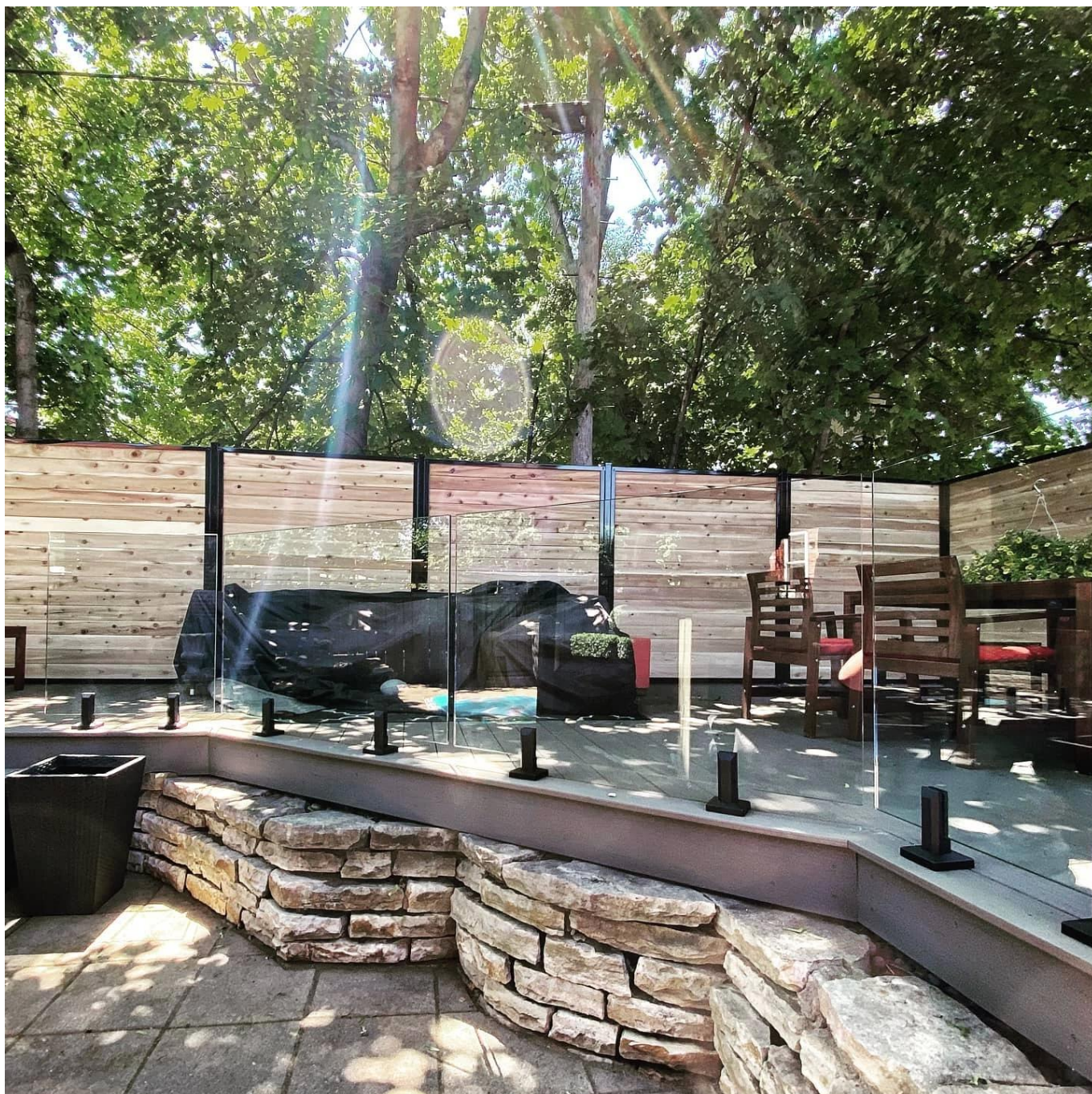

Contact Information

Any inquiries or questions, please leave a message. Will get back to you as soon as possible!

For any urgent enquiry, please get in touch below:

Contact: Wendy

Email: sales04@launch-china.cn

Mob/WhatsApp/WeChat: +0086 159 8933 9827

CONTACT US

WELCOME TO CONTACT US. WE WILL DO OUR BEST TO HELP YOU!

- ✓ Name: Wendy
- ✓ Email: sale04@launch-china.cn
- ✓ Mobile/Whatsapp/Wechat: +86 159 8933 9827