

Stainless Steel Square Core Drill [Spigot](#) for Frameless Glass Railing Design

Feature



- Model No.: SCM-2 (square core drill spigot)
- Material: stainless steel 316 (duplex 2205 is available)
- Finish: mirror polished or satin brushed
- For [10-13mm glass](#)
- Hight: [285mm, 90mm fixing into ground](#)
- Net weight: 1.565kg/piece
- Manufacture method: casting
- Sample: available to check quality before order

Glass Railing Spigot Details



- mirror polished glass spigot



-satin brushed glass spigot



-spigot technical drawing

Project name

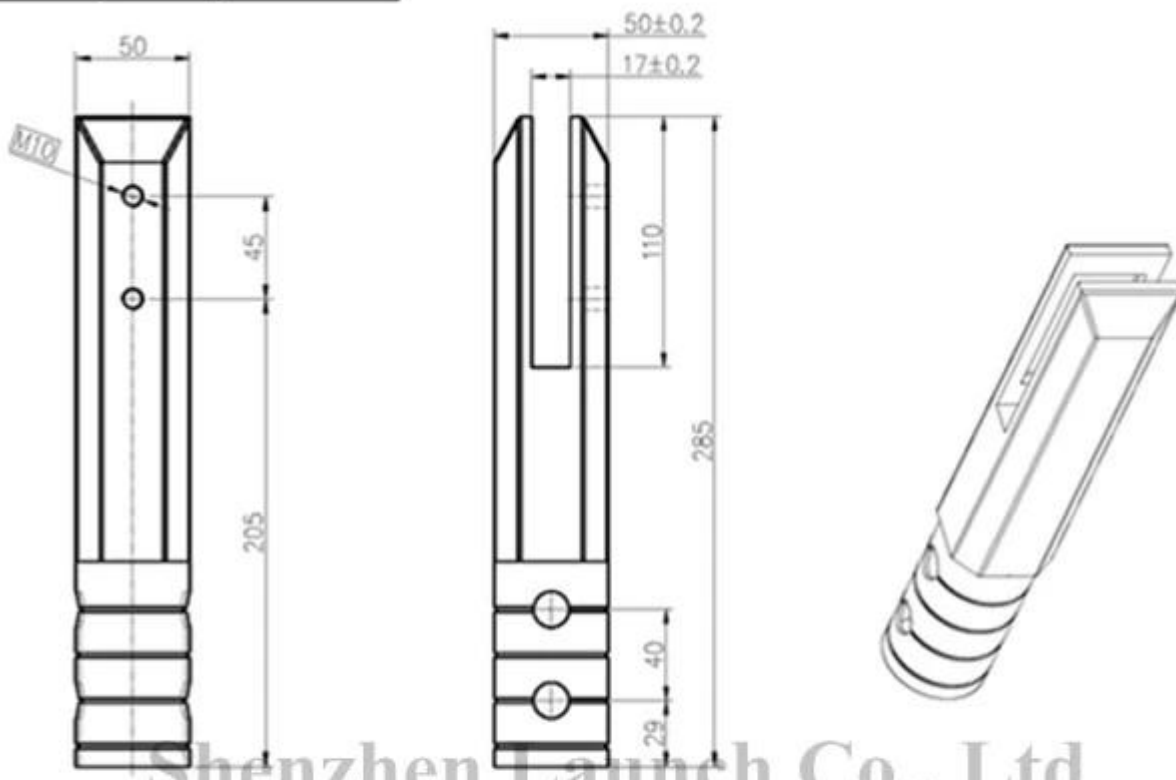

Shenzhen Launch Co., Ltd

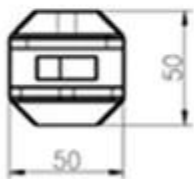

数量共页第页

深圳市朝临商贸有限公司 SHENZHEN LAUNCH CO., LTD.		表面处理
设计	裴佳辉	材料
校对		图号:SCM
工艺		名称:Spigot
审核		版次
批准		Y001

- spigot safe packaging
- one piece into one plastic bag, then into one white box.
- 12 pieces into one carton.
- or as per customers requirement.



Glass Spigot Project Pictures

-Square core drill spigot for glass pool fence design



-Square spigot for balcony glass railing design



-Square spigot for frameless glass garden balustrade



Factory



- Factory is in Dongguan Guangdong, China.
- Factory inspection is welcome.



Need a quote or any questions, please leave a message.
Or contact me as below info. will get back to you ASAP!

For any urgent enquiry, please get in touch on wechat: 973219879 or what's up: +86-13530506265.

KEBIL 科比奥®

深圳市朗驰商贸有限公司
SHENZHEN LAUNCH CO., LTD.

朗驰国际有限公司
LAUNCH INTERNATIONAL LIMITED.

董萍 Doris Dong

Senior Sales Representative

☎ (86) 135 3050 6265

深圳市南山区南山大道1092号亿利达大厦B区3栋5003

Room 5003, Building 3, Yilida Building, No.1092
Nanshan Road, Nanshan District, Shenzhen, China
postal code 518054

☎ (86-755) 8603 7559

☎ (86-755) 8637 2611

✉ sales04@launch-china.cn

🌐 www.launch-china.com
www.chinabalustrade.com