

stainless steel 316 glass spigot for pool fencing concrete or timber decking
frameless glass railing

Square base plate SBM stainless steel spigots specification,

1. Material: Stainless steel 316/duplex 2205.
2. Finish: Satin or mirror polished.
3. For glass thickness: 10-13.52mm.
4. Model No. SBM: Square base plate spigot.
5. Dimension:
 - Height: 168MM;
 - Width: 50 mm round;
 - Groove height: 110mm;
 - Groove to bottom: 58mm;
 - Base diameter: 98mm;
 - Cover plate diameter: 100mm;
 - 2 x M8 grub screws, SS316 pressure plate, special high quality rubber gasket.
 - 100mm diameter dress ring/ cover plate to suit the square spigot for hiding visual fixings (cover plate must be used with installation).

Glass Spigot SBM :



SBM

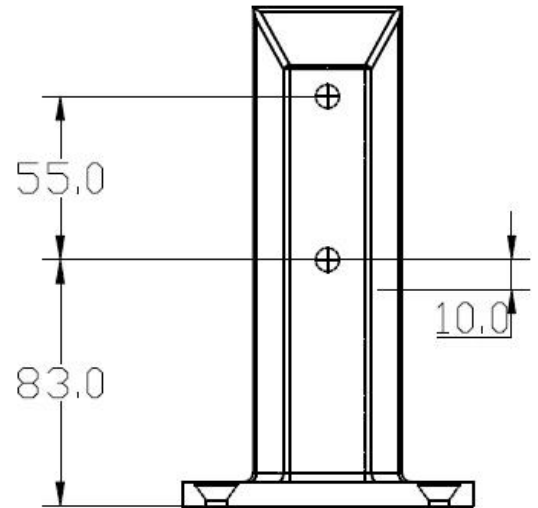
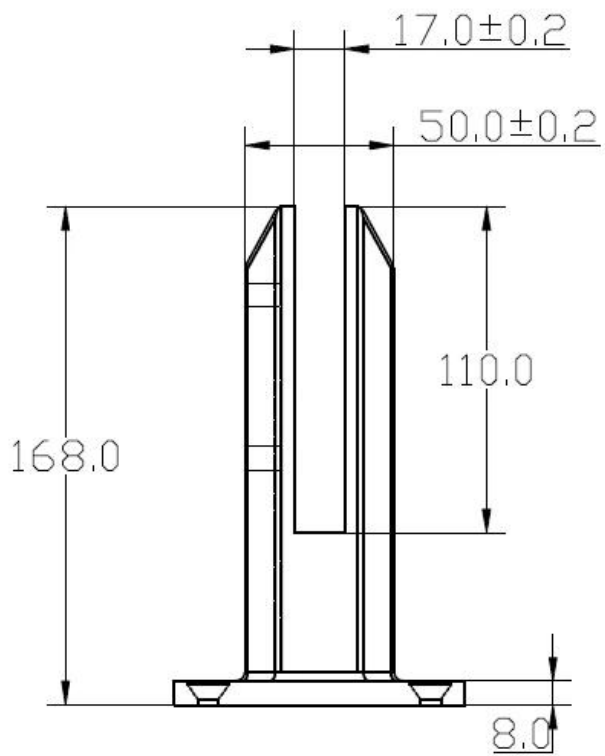

Material:

Marine grade 316 Stainless Steel material to maximize the products life and appearance. This premium quality material is low carbon, anti rust, tough, durable, excellent resistance to corrosion, suitable for outdoor uses.



[Glass Spigot SBM Application:](#)

Stainless steel glass spigots used for fixing glass of swimming pool fencing walls for outdoor living, antirust and very durable.

Nice-

looking mini posts apply to support 10 or 12mm fully frameless glass for fence in home & garden.

Glass gator clamps for the construction of glass handrails for a beautiful stair balustrade or balcony.







[Glass Spigot SBM DIY Installation:](#)

1. Mark out the centre line of proposed glass fence.
2. Determine spigot location and mark out the hole positions, drill the required holes.
3. Bolt the base plated spigot into position using the expansion screws for concrete/pavings/tiles or timber screws for wooden decking.
4. Fit the cover plate prior to installing frameless glass.
5. Install the glass to the spigots and tighten the clamp with supplied Allen key.



fixing method: base plate spigots

Mark out the centre line of proposed glass fence with a chalk line. Determine clamp location based on a sheet size (recommendation on pages 1 & 2). Use base plate as a template to mark out the hole positions and drill holes to suit.

Note: Do not exceed 100mm gaps between glass panels. Optimum gap is 40mm to 60mm

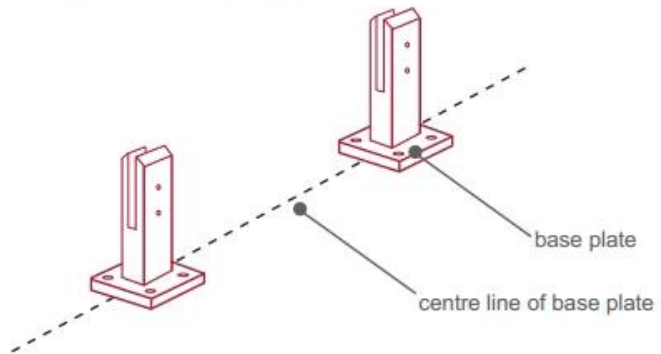

Now the base plated spigots can be fitted to the floor and plumbed via shims (not supplied) under the base plates. Be sure to tighten firmly as the smallest of movement at the base plate will result in noticeable movement at the bottom of the glass fence.

Tip: By setting the two outer spigots of your total span, a string line can be run in the 'throat' of the spigots, giving correct height for all spigots in between

Note: Do not exceed 100mm gap from the fixing surface to the bottom of the glass

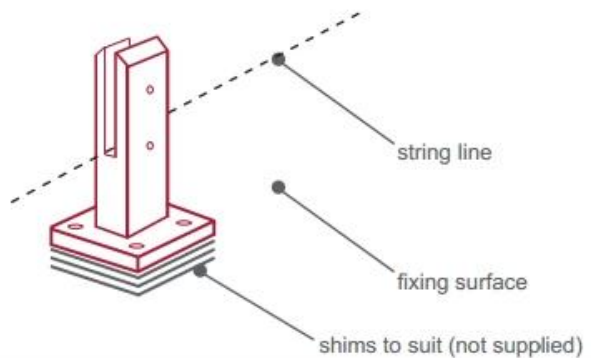

When all spigots are installed, slip domical cover the top of the spigot to hide fixings. It will be necessary to turn the adjustment screws on the spigot face all the way in to allow cover to pass over

Note: Same installation method applies to round base plate spigot

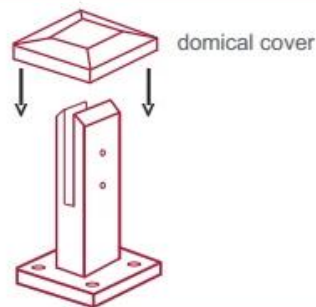

The glass is then installed to the spigots. Place plastic packers between glass & spigot, at no stage should glass touch the metal

How adjustability works:

1. Place glass in spigot
2. Fix/ tension glass both sides with allen key

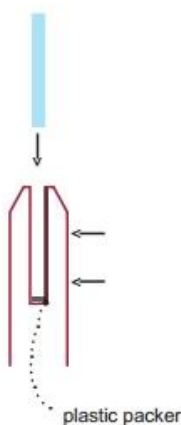

Glass Spigot SBM Packaging:

Each glass spigot with 1 cover fitted is wrapped up with one air foam bag to protect from scratches.

Each spigot with foam bag is put into 1 carton box.

4 pcs expansion screws & 4 sets timber screws for installation wrapped by thick

rubber hose is put together with 1 spigot.

4 small boxes are packed in 1 big carton box.

1 set installation tool allen keys free supplied in 1 big box.

Each big carton box is individually wrapped up with wrapping film & packing tapes.



Thanks for your visit, Any interested or needs, please contact with me freely :

Joey Lan

Shenzhen Launch Co., Ltd

www.launch-china.cn www.chinabalustrade.com

Email: sales02@launch-china.cn .

Skype: launch-02 . Office: 86-755-86037559 .