

Почему выбирать SHENZHEN LAUNCH ?

SHENZHEN LAUNCH является проверенный по SGS , все металлические изделия из наш Компания находятся проверенный с участием отлично качество.

Alibaba.com Gold Plus Supplier

Main Product Lines Verification Report

Presented to

Shenzhen Launch Co., Ltd.

深圳市朗驰商贸有限公司

Company Address	B5003, Building 3, Yilida Building, No. 1092 Nanshan Avenue, Dengliang Community, Nanshan Street, Nanshan District, Shenzhen City, Guangdong Province, China
Consigner of Assessment:	Alibaba
Gold Supplier Member ID:	launch168
Gold Supplier Company Name:	Shenzhen Launch Co., Ltd.
Contact Person:	Mr. Binfeng Gao
Phone Number:	0086-13802569770
Fax Number:	0086-755-86372611
Email:	gbf999@china.com
Website Address (URL):	http://launch-china.en.alibaba.com

*Service Provided by SGS
Report No.: 19536352_P+T*





Cutting Machine	XN	4	3	Acceptable
Laser Cutting Machine	MPS-3015D	1	2	Acceptable
4.5M CNC Processing Center	PRATIC	1	3	Acceptable
CNC Processing Meter	JNC	8	3	Acceptable
Shearing Machine	6X2500	2	3	Acceptable
Bending Machine	AG-1030II	4	3	Acceptable
Punching Machine	N/A	36	6	Acceptable
Coating Line	N/A	1	1.5	Acceptable
Lathing Machine	N/A	1	6	Acceptable
Grinding Machine	LITAO	4	6	Acceptable
Milling Machine	TONG ZHENG	2	6	Acceptable
Welding Machine	N/A	5	5	Acceptable
Tube Processing Machine	N/A	2	5	Acceptable
Cutting Machine		Laser Cutting Machine		4.5M CNC Processing Center
				
CNC Processing Meter	Shearing Machine		Bending Machine	
				
Punching Machine	Coating Line		Lathing Machine	
				

Report No:	19536352_P+T	Report Date:	09/Oct./2019	Assessed By	Wlof Wang
CONFIDENTIAL		All Rights Reserved		Page No:	6 of 10

лестничные перила 1/2 "стеклянный боковой монтаж стеклянный кронштейн популярный дизайн для внутренних перил.

1. Технические характеристики стеклянного кронштейна -

1. Модель № SF-50
2. ДИАМ 50мм
3. Для стекла толщиной 10-19 мм
4. MOQ 10 шт
5. с болтом M12 * 120 для крепления на бетоне или шурупом для дерева M12 * 72 для крепления на дереве
6. 7,1 долл. США / шт на основе более 100 шт.

2. Фотографии лестничных перил 1/2 "стеклянная боковая опора



3. чертеж для SF-50

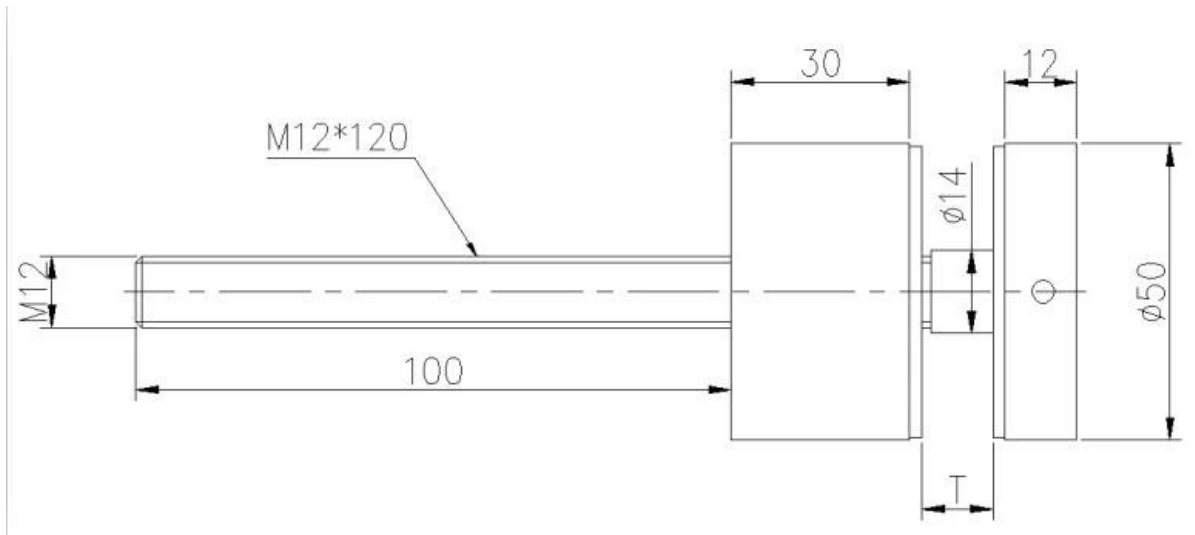

4. Больше моделей кронштейнов -



Part No.	Material	Finish	Body	Bolt size
▪ SF-30	▪ AISI 304 ▪ AISI 316	▪ Satin ▪ Mirror	▪ 30x10; 30x25mm	▪ M10x120 bolt ▪ M10x72 wood screw ▪ M8x100 bolt ▪ M8 x72 wood screw
▪ SF-40			▪ 40x10; 40x30mm	
▪ SF-50			▪ 50x12; 50x30mm	
▪ SF-50A			▪ 50x12; 50x50mm ▪ silicon rubber gasket included	



Part No.	Material	Finish	Body	Bolt size
▪ SF-38Z	▪ AISI 304 ▪ AISI 316	▪ Satin ▪ Mirror	▪ hollow type ▪ 38x7.5; 38x38mm ▪ silicon rubber gasket included	▪ M8x70 hexagonal screw



Part No.	Material	Finish	Body	Mounting plate size
▪ SF-50T	▪ AISI 304 ▪ AISI 316	▪ Satin ▪ Mirror	▪ 50x10; 50x30mm ▪ silicon rubber gasket included	▪ 200x100x10mm